



An ITW Company

R50 Blue Bar and Power Supplies

(D, N & TRUEAC)

INSTALLATION AND OPERATING INSTRUCTIONS

TABLE OF CONTENTS

1. SAFETY WARNINGS.....	1
2. DESCRIPTION	2
R50 Blue Bar.....	2
“N” Power Supplies.....	2
“D” Power Supplies.....	2
TrueAC Monitoring Power Supplies.....	3
Receipt of Equipment	3
Return Shipments	3
3. SPECIFICATIONS	4
4. INSTALLATION.....	6
R50 Blue Bar.....	6
“N” Power Supply.....	7
“D” and TrueAC Power Supply.....	9
5. OPERATION	14
Startup for “N” Power Supplies.....	14
True AC Function Indicators.....	14
Calibration Instructions for the TrueAC Monitoring Power Supply.....	14
Calibration Procedures	14
6. TROUBLESHOOTING	17
Troubleshooting for “D” Power Supply.....	17
Operating Condition Solutions.....	17
Indicator Light Solutions.....	17
7. MAINTENANCE.....	18
R50 Blue Bar.....	18
Functionality Check of “N” Power Supplies.....	19
8. REPLACEMENT PARTS	20
9. WARRANTY.....	21

1. SAFETY WARNINGS

NOTE! – Statements identified with a **NOTE** indicate precautions necessary to avoid potential equipment failure.

CAUTION! – Statements identified with a **CAUTION** indicate minor or moderate injury is possible.

WARNING! – Statements identified with a **WARNING** indicate serious injury is possible.



NOTE! – This equipment must be correctly installed and maintained. Adhere to the following notes for safe installation and operation.

1. Read instruction manual before operating or installing device.
2. Qualified service personnel must do installation and repairs.
3. Ground the frame of the machine on which the power supply and neutralizing bars are mounted.
4. Disconnect supply voltage to power supply before connecting neutralizing bar to the high voltage terminal strip.



CAUTION! – **Electrical Shock Hazard**

1. Do not touch bar when power supply is energized.
2. Disconnect supply voltage to power supply before connecting bar or performing any maintenance to the system.



WARNING! – **Fire Hazard**

Do not install or operate equipment in close proximity to any flammable solvents or flammable materials.

2. DESCRIPTION

Simco-Ion's N167, N257, N267, D167Q, D257Q, and TrueAC power supplies are designed as a power source for the static neutralizing R50 Blue Bar. The R50 Blue Bar is used to eliminate or significantly reduce static charges that disrupt manufacturing processes. The high voltage from the power supply causes the ionizing pins of the static neutralizing bar to generate both positive and negative ions from the surrounding air molecules. The static charge on the material being processed will attract and combine with the oppositely charged ions, causing the material to be neutralized. The excess ions either recombine in air or dissipate to ground.

R50 Blue Bar

The R50 Blue Bar is current limited shockless bars with resistors in series between each emitter pin and the high voltage source. The Blue Bars incorporate an encapsulated internal ground reference. The current-limited design provides an added safety feature to prevent hazardous electrical shocks if there is contact with the ionizing pins. This safety feature does not compromise the static bar's performance.

Features

- Current limited to prevent electrical shock from contact with ionizing pins
- Built-in ground reference inside bar for maximizing ion generation
- Flexible shield high voltage cable to limit EMI and RFI
- Continuous mounting slot to allow installation flexibility

"N" Power Supplies

The Simco-Ion Type N Power Supply provides multiple high voltage outputs for powering various types of static eliminating equipment. Although there are various models, they are basically the same with respect to mounting, connection, and operation.

Each power supply operates on a specific line voltage and frequency and provides a specific high voltage output. The voltage of the power supply needed depends upon the type of static eliminating device it is to power. Therefore, the power supply must be used only with the device for which it was originally supplied. Do not add any device to the power supply without first consulting Simco-Ion.

If it should become necessary to contact Simco-Ion regarding the power supply, please be sure to reference the power supply model number and unit number. These numbers are listed on the label affixed to the power supply. Line voltage and frequency requirements as well as output ratings are listed on the nameplate.

The Simco-Ion Type N Power Supplies are UL and CSA listed. These power supplies also carry CE approval.

"D" Power Supplies

The D167Q and D257Q power supplies are neither equipped with a monitoring circuit nor have provisions for remote monitoring. The D167Q and D257Q power supplies

consist of a ferroresonant type transformer rated at 7,000 volts, 3 mA with short circuit current limit of 5.0 mA. These potted power supplies are equipped with output outlets to facilitate up to two static neutralizing bars.

Features

- High impedance transformer design with short circuit current limited to 5.0 mA maximum
- Outlets to accommodate up to two neutralizing bars
- Potted transformer in metallic enclosure

TrueAC Monitoring Power Supplies

The TrueAC power supply is equipped with a monitoring circuit with provisions for remote On/Off control and remote monitoring. The units are designed to operate with the R50 Blue Bar to provide monitored static control performance on stationary objects or on materials traveling at speeds up to 2,500 feet per minute. The power supplies consist of the monitoring circuit and a ferroresonant type transformer rated at 7,000 volts, 3 mA, with a short circuit current limit of 5 mA. The units are equipped with output outlets to facilitate up to two static neutralizing bars.

Features

- Bar ON indicator
- Bar OFF indicator
- Remote display capabilities for CLEAN BAR*, FAULT*, and SERVICE*
- CLEAN BAR Indicator – factory set at 40% of maximum bar efficiency, or can be set by user in the field
- FAULT indicator
- BAR PERFORMANCE RANGE Indicator
- Arc Detection circuit

* Dry contacts available via remote connector included with the unit.

Receipt of Equipment

1. Carefully remove the equipment from the carton.
2. Inspect contents for damage that may have occurred during shipment. If any damage has occurred during shipment, the local carrier should be notified at once. A report should be forwarded to Simco-Ion, 2257 North Penn Road, Hatfield PA 19440 and (215) 822-6401.
3. Empty the carton to insure that small parts are not discarded.

Return Shipments

Prior to returning goods, contact a Simco-Ion Customer Service representative for a Return Authorization Number. This number should be included on the packing list. All correspondence should also reference the Return Authorization Number. Any item being returned should be shipped prepaid and packed to provide adequate protection.

3. SPECIFICATIONS

R50 Blue Bar	
Operating Voltage	R50-8,000 VAC max, 50/60 Hz
Ionizing Pin Current	R50-48 mA with 7200 VAC applied voltage, short circuit
Operating Temperature	176°F (80°C) max
Humidity	70% RH max, no dewing permissible
Dimensions	5/8"W x 1 1/4"H x Overall Length (OL) (see Figure 1)
Weight	0.5 lb/ft
Enclosure	Glass-fiber-reinforced plastic (GRP)
Encapsulation Material	Polyurethane, UL-94 V-0
Installation Hardware	Plastic slider and nylon bolts

"D" Power Supply		
Part Number	4000074 (D167Q)	4000075 (D257Q)
Input Power Rating	120 VAC 60 Hz	230 VAC 50/60 Hz
Output Voltage	7 kV AC	
Output Current	3.0 mA max, 5.0 mA short circuit	
Temperature	105°F (40°C) max, ambient	
Dimensions	5.8"L x 4.0"W x 3.4" H	
Weight	7 lbs	
High Voltage Connector	Two screw-in type connectors	

"N" Power Supply			
Part Number	4002321 (N167)	4002337 (N257)	4002322 (N267)
Input Power Rating	120 VAC 60 Hz	230 VAC 50 Hz	230 VAC 60 Hz
Output Voltage	7 kV AC		
Output Current	3.0 mA max, 5.0 mA short circuit		
Temperature	105°F (40°C) max, ambient		
Dimensions	8.6"L x 4.9"W x 4.5" H		
Weight	7 lbs		
High Voltage Connector	Four terminal block connections		

TrueAC Power Supply		
Part Number	4010442	4010443
Input Power Rating	120 VAC, 50/60 Hz	230 VAC, 50/60 Hz
Output Voltage	7 kV AC	
Output Current	3.0 mA max, 5.0 mA short circuit	
Temperature	105°F (40°C) max, ambient	
Dimensions	5.5" L x 3.9" W x 4.5" H	
Weight	6 lbs	
High Voltage Connector	Two screw-in type connectors	

R50 Bar Profile

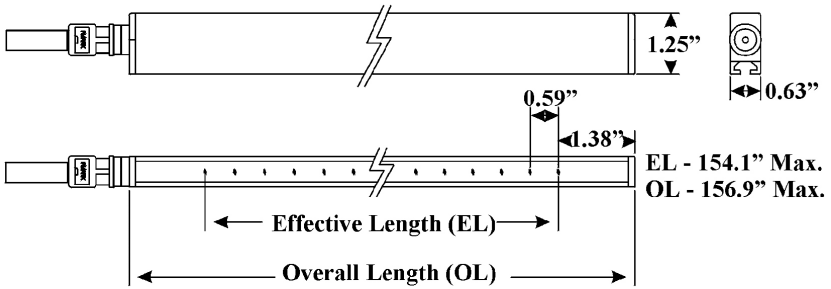

Axial Connector with Non-Detachable Cable

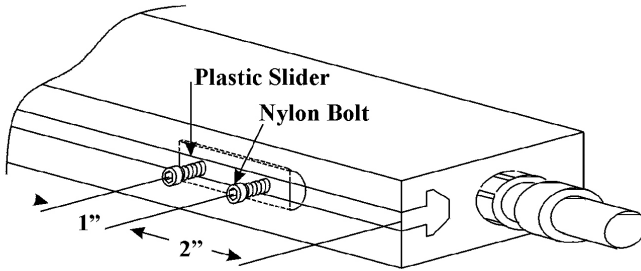

Figure 1. R50 Blue Bar Overview and Dimensional Drawing

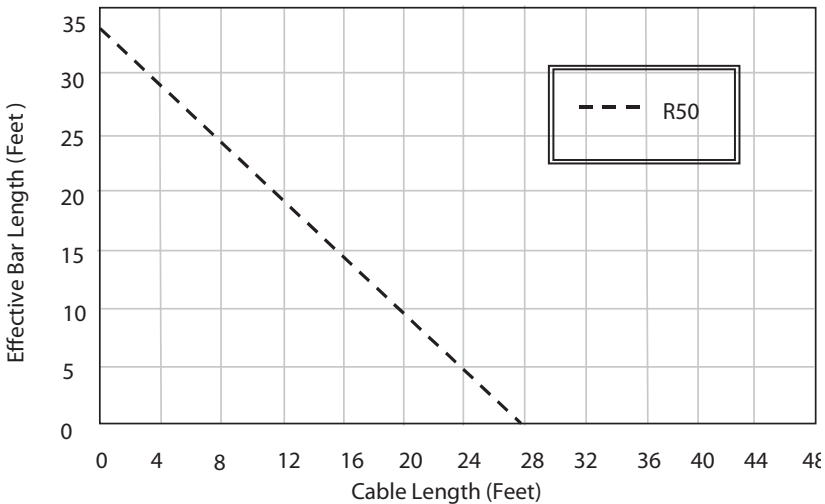

Figure 2. Loading Capacity

4. INSTALLATION

R50 Blue Bar



CAUTION – Electrical Shock Hazard

DO NOT use metallic screws. DO NOT omit insulator blocks.

- 1 Mount bar to machine. Bar should be positioned away from all metal ground references. In an ideal mounting arrangement, a cylindrical space with radius R between bar and web should be kept free of any grounded metal structure. In the event of confined mounting space, the minimum distance that a bar should be located from a nearby metal ground reference is 1”.
2. Determination of radius R depends on web speed. For varying web speed, radius R should be 2” from web surface. Refer to **Figure 4** for maximum mounting distance of bar from web surface. In certain applications, the Blue Bar has been found to work well at distances in excess of 6”.



CAUTION – Mounting the bar directly against a grounded metal support without sufficient air space or plastic insulation could result in burn-out of the bar.

3. Insert nylon screws through washers, then metal bracket, insulation block and finally into the sliding nuts supplied with each Blue Bar (see **Figure 4**).
4. Hand-tighten screws plus ¼ turn. Do not over-tighten. For permanent mounting, apply liquid thread-lock to screw prior to assembly (Loctite 243 or equivalent).



CAUTION – Failure to properly ground the power supply may result in an electrical shock hazard to personnel and inefficient operation of the equipment. Do not apply line power until all grounds and high voltage connections have been completed.

“N” Power Supply

Mounting and Grounding the Power Supply

The power supply is designed for flat surface mounting and can be easily mounted using the mounting flanges at the base of the unit. The ambient temperature of mounting area of the power supply must not exceed 105°F (40°C).



CAUTION – Electrical Shock Hazard

Failure to properly ground a power supply may result in an electrical shock hazard to personnel and inefficient operation of equipment.

Proper grounding of the power supply enclosure is essential for safe and efficient operation. Proper grounding can be accomplished by either of the following methods:

1. For power supplies mounted on machinery, connect power supply ground stud with at least #16 AWG copper wire.
2. All power supplies are equipped with a 3-conductor line cord.

For power supplies with 120 VAC operating voltage, the line cord is fitted with a standard NEMA 5-15P plug. The line cord must be plugged into a 3-terminal grounded receptacle.

For power supplies with 230 VAC operating voltage, the line cord is fitted with a standard NEMA 6-15P plug. The line cord must be plugged into a 3-terminal grounded receptacle.

For power supplies that are equipped with a plug-less 3-conductor line cord, the ground wire (green or green/yellow) must be connected to earth ground.

Input Line Voltage Connections

The line cord must be connected to a power source of the correct voltage and frequency as listed on the nameplate. For power supplies with 120 or 240 VAC operating voltage, the line cord is fitted with a plug. For power supplies with a plug-less line cord, the following connections are required:

Wire Colors		
North America	International	Power Connection
Black	Brown	Live
White	Blue	Neutral
Green	Green/Yellow	Ground

If the static eliminating equipment is used on machinery, it is recommended that the line cord of the power supply be connected to the machine “RUN” button. This enables the static eliminating equipment to turn on and off with the machine. Some power supplies are equipped with an ON/OFF switch with indicator.



CAUTION – Electrical Shock Hazard

Do not apply line voltage to the power supply until all grounds and high voltage connections are complete and static eliminating equipment has been installed.

High Voltage Connections for Standard Cable

When connecting high voltage cable through the high voltage outlets of the power supply enclosure, always install the strain relief bushing onto the cutout to insulate cable and prevent it from arcing to ground. Refer to the installation procedures below:

1. Disconnect line voltage to power supply
2. Remove lid from power supply
3. Remove black insert bushing from cutout of high voltage outlet. Mount strain relief bushing (supplied with power supply) on cutout.
4. Insert cable through strain relief bushing. Allow cable to reach high voltage output terminal block inside power supply.
5. Strip 3/8 inch insulation from end of high voltage cable. Attach cable to one of the free positions on the high voltage output terminal block.
6. Re-tighten strain relief bushing to fit snug. Pull gently on cable to make certain connection is secure.

Some static eliminating devices may have a separate insulated ground wire (green) running along the high voltage cable. This wire must be connected to the ground terminal on the power supply.

If corona-free shielded cable is used, be sure to connect ground wire to ground terminal located inside the power supply.



CAUTION – Electrical Shock Hazard

Failure to properly ground shielding may result in electrical shock hazard to personnel and inefficient operation of equipment.

“D” and TrueAC Power Supply

1. Determine the location for mounting the neutralizing bar and power supply. Refer to **Figure 8** (see **Figure 9** for TrueAC cable connections) for correct cable assembly. Some cable assemblies have SLCC high voltage connector pre-installed.
2. **DO NOT PLUG LINE CORD OF POWER SUPPLY INTO THE INPUT POWER RECEPTACLE UNTIL INSTALLATION IS COMPLETED.**
3. Drill four 9/32” diameter clearance holes for mounting the power supply using ¼-20 hardware. Refer to **Figure 10** for dimensions between clearance holes.
4. Ensure the mounting location of the power supply will allow the high voltage cables to be positioned away from moving parts and sharp edges then mount power supply.
5. Connect a ground wire to the ground terminal of the power supply. (See **Figure 12** for ground terminal location)
6. Mount the neutralizing bar using the hardware provided with the shipment. Refer to R50 Blue Bar installation instructions in Section 4 for details.
7. Proceed to section on attaching high voltage cable to “D” and TrueAC.
8. Plug line cord into receptacle to energize power supply.

SLCC High Voltage Connector Assembly

The equipment you have ordered may be supplied with a spring-loaded connector installed. If so, keep these instructions for use when ordering a replacement connector. If the spring-loaded connector is not installed, follow the instructions below, using **Figure 8** as a guide.

1. Slide knurled plug (knurled end first) over the end of the cable that will be inserted into the power supply.
2. Slide connector body (end without setscrew hole first) over cable.
3. Slide high voltage connector (small metal piece with threaded hole for setscrew) over gold tip at end of connector wire. Line up setscrew hole in connector body with hole in high voltage connector.
4. Insert setscrew in connector through the hole in the connector body and tighten until setscrew is just even with or slightly below the surface of the connector body.
5. Pull firmly to be sure high voltage connector is tight on conductor wire.
6. Turn contact spring (end with close turns) clockwise, by hand, onto high voltage connector until spring butts against connector body.

Attaching High Voltage Cable to “D” and TrueAC Power Supply

1. Switch off power supply and unplug line cord from receptacle.
2. Insert SLCC high voltage connector in female port on the power supply and finger-tighten (see **Figure 13** for TrueAC).

- For “D” connect ground wire to ground terminal of power supply. For TrueAC, connect shield wire to shield terminal of power supply (see **Figures 12** and **13**)

Removing High Voltage cable from “D” and TrueAC Power Supplies

- Switch off power supply and unplug line cord from receptacle.
- For “D” remove ground wire of cable assembly from ground terminal. For TrueAC, remove shield wire of cable assembly from shield terminal (see **Figure 13**).
- Carefully finger-loosen SLCC connector and remove cable from power supply.

Mounting Bracket Requirements per Bar (overall length):

- Up to 3.25 feet: 2 brackets
- Up to 6.50 feet: 3 brackets
- Up to 8.75 feet: 4 brackets
- Up to 13.0 feet: 5 brackets

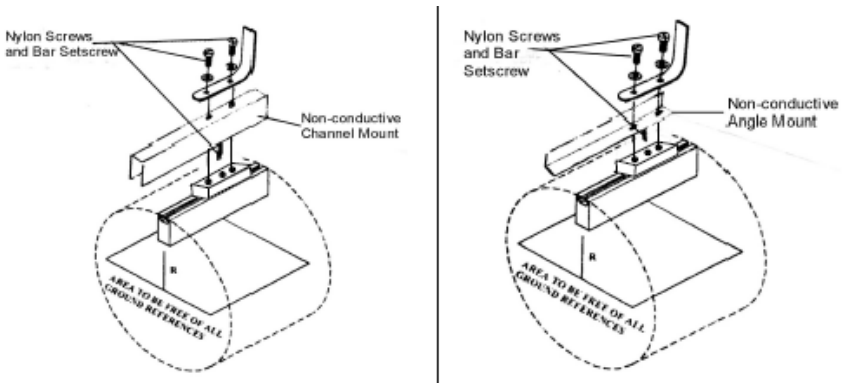

Figure 3. Installation of R50 Blue Bar with Distance from Ground Reference

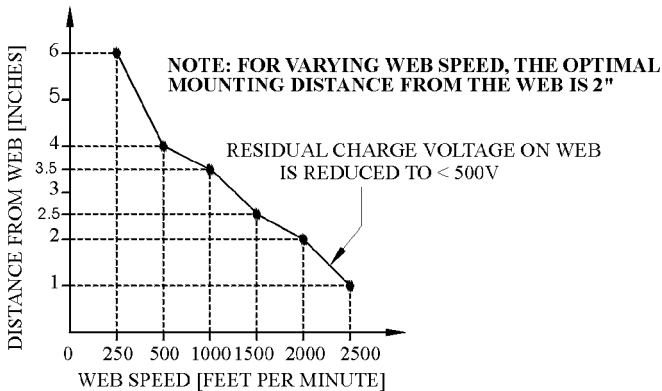

Figure 4. Optimal Mounting Distance of Blue Bar at Various Web Speeds

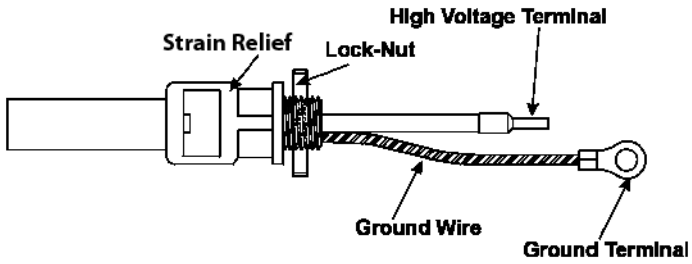

Figure 5. Cable Assembly for "N" Power Supplies

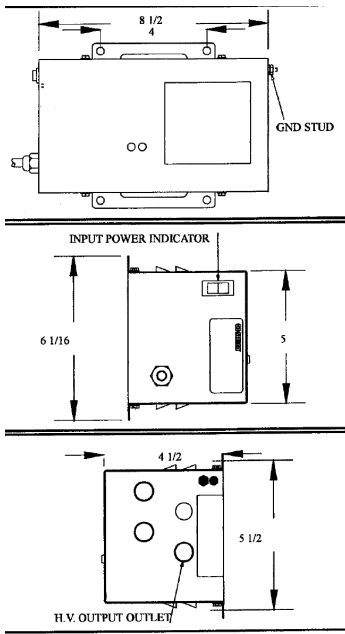

Figure 6. Outline Drawings of Type N Power Supplies

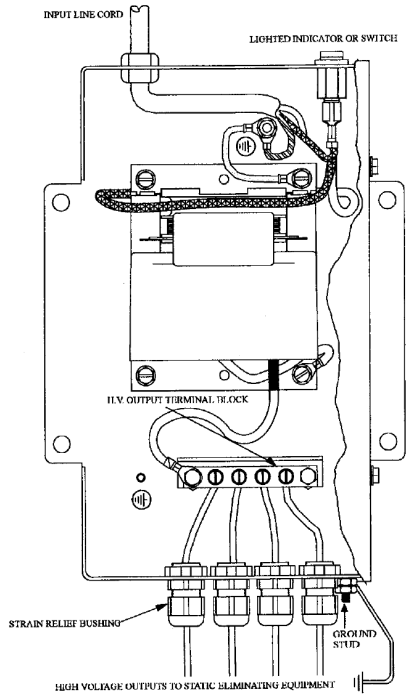

Figure 7. High Voltage Output Connections of "N" Power Supplies

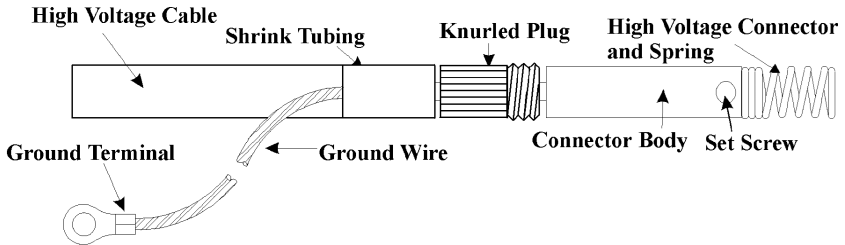

Figure 8. Cable Assembly and Connector Kit for "D" Power Supplies

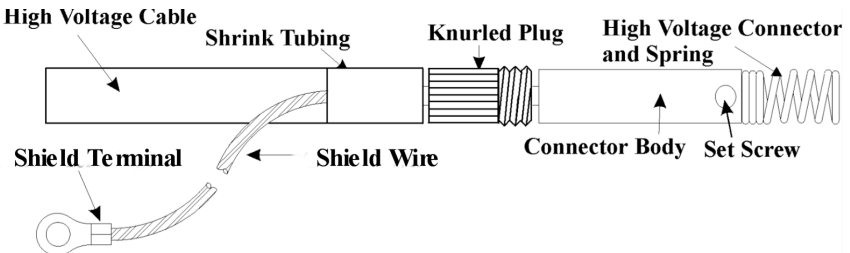

Figure 9. Cable Assembly and Connector Kit TrueAC Power Supplies

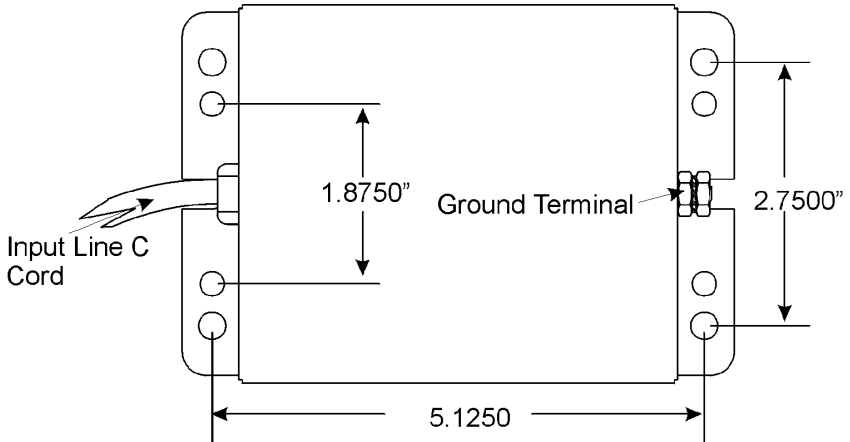

Figure 10. Mounting Holes for "D" Power Supply

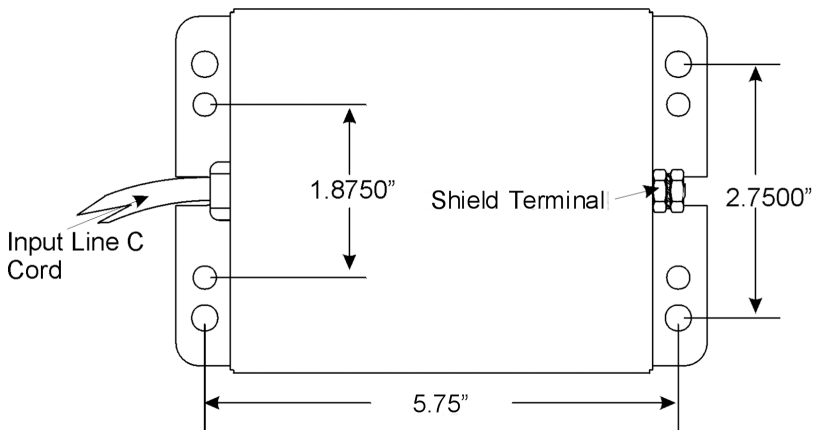

Figure 11. Mounting Holes for TrueAC Power Supplies

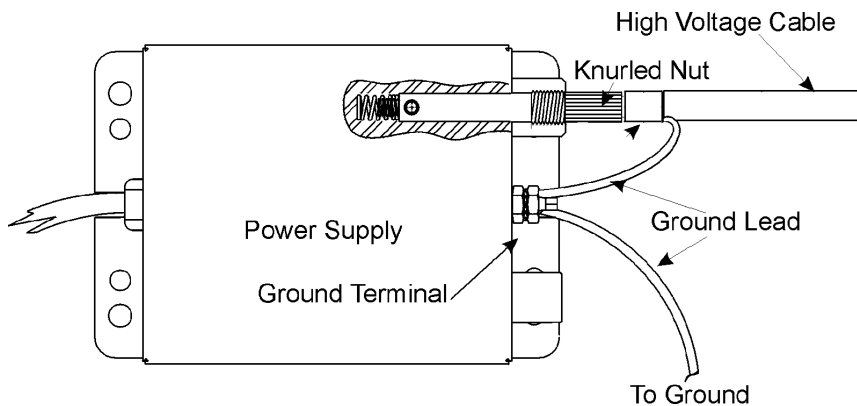

Figure 12. Installation of High Voltage Cable Assembly to "D" Power Supplies

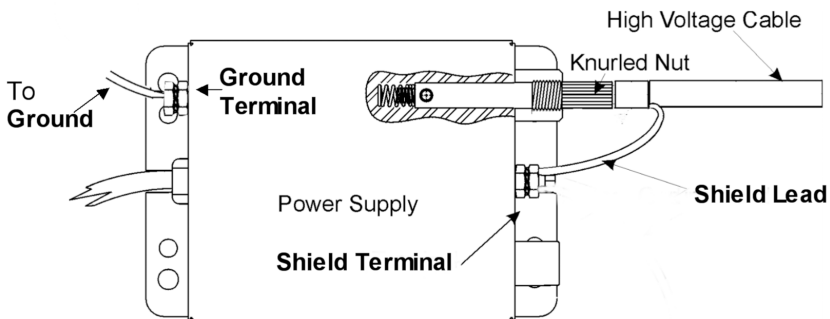

Figure 13. Installation of High Voltage Cable Assembly to TrueAC Power Supplies

5. OPERATION

Before switching on power supply, ensure that power supply is properly grounded and static bar properly assembled and installed.

Startup for “N” Power Supplies

To operate the static eliminating equipment, apply line voltage to the power supply. For power supply equipped with an ON/OFF switch, place the switch in the ON position.

True AC Function Indicators

1. BAR ON – High voltage is present on the static bar
2. BAR OFF – No high voltage on the static bar or cable
3. CLEAN BAR – Tells the machine operator when it is time to clean a dirty static bar. Also has a remote dry contact output.
4. FAULT – The Arc Detection portion of the circuit turns the power supply off if the high voltage is shorted to earth ground to alarm that there is a system failure and protect the transformer. Also has a remote dry contact output.
5. SERVICE – Illuminates when an insulator covers the static bar emitter pins and ion production has stopped. Also has a remote dry contact output.
6. BAR PERFORMANCE – Bar graph displaying the ionization output performance of the static bar.

Calibration Instructions for the TrueAC Monitoring Power Supply

Calibrating the TrueAC Monitoring Power Supply is a simple process using the two calibration pots located on the face of the power supply. The “Clean Bar” light is preset at the factory to illuminate when the ionization output from the static bar is at approximately 40% of maximum output potential, however, it can also be re-calibrated in the field to either increase or decrease the sensitivity of the monitoring system, depending on the users requirement. Normally the monitor will require calibration only at the initial set-up. Re-calibration may be required several days later as a result of changes that may occur during the burn-in period experienced by new bars.

Calibration Procedures

Initial Set-up

Since the clean bar light is pre-set at the factory, the “Bar Monitor Set-Up” is the only calibration requirement. Calibrate the light as follows:

1. Mount the static bar(s) in its permanent location directed toward a web or a roll of material. The production line should be stopped during the calibration procedure.
2. Connect the bar(s) to the power supply. Attach the pigtail lead at the connector end of the static bar cable to the metal stud located above the female connector ports on the power supply.



NOTE – Please note that this connection point is part of the monitoring circuitry, and IS NOT a ground connection. Any ground connection at this point will cause the SERVICE circuit to activate.

3. Turn on the power. The BAR ON and SERVICE lights will illuminate, and there will be no lights illuminated on the “Bar Performance” grid display.
4. Locate the pot marked “Bar Monitor Set-Up” that is located above the service light.
5. Use a very thin bladed screwdriver to adjust the pot, either left or right, until the light on the “Bar Performance” grid illuminates. Continue to turn the pot until the SERVICE light extinguishes, then continue for 1/8 turn.
6. The calibration is complete.

Calibrate the Clean Bar Set-up

The “Clean Bar” light is preset at the factory, however, it can be re-calibrated in the field to change the sensitivity of the monitoring system. Calibrate the display as follows:

1. Mount the static bar(s) in its permanent location directed toward a web or a roll of material. The production line should be stopped during the calibration procedure.
2. Connect the bar(s) to the power supply. Attach the ground lead at the connector end of the static bar cable to the metal stud located above the female connector ports on the power supply.



NOTE – Please note that this connection point is part of the monitoring circuitry, and IS NOT a ground connection. Any ground connection at this point will cause the fault circuit to activate.

3. Turn on the power.
4. Locate the pot marked “Bar Monitor Set-Up”, just above the SERVICE light.
5. Use a very thin bladed screwdriver to adjust the pot, either left or right, to move the “Bar Performance” indicator light to the desired level on the performance grid where the clean bar light would activate.
6. Once the desired alarm level has been reached, move to the “Clean Bar Set-Up” pot located above the clean bar light. Slowly turn the pot, left or right, until the “Clean Bar” light illuminates.
7. Move back to the “Bar Monitor Set-Up” pot, slowly turn the pot to move the “Bar Performance” indicator light down the grid display until it approaches the base of the normal range on the grid and the SERVICE light illuminates. At this point, slowly turn the pot in the opposite direction until the SERVICE light extinguishes, then continue for 1/8 turn.
8. The calibration is now completed.

Other Display Lights on the True AC Monitoring Power Supply

Local/Remote Switch – Set the switch in local mode unless connecting a voltage signal from 12 to 24V, 1A max. for remote on/off operation to the remote connections located

adjacent to the AC power switch. Contact Simco-Ion for instructions on how to connect for remote operation.

Bar Off – Will only illuminate when operating in remote mode and the power supply is remotely turned off.

Bar On – Will illuminate when there is AC line power to the power supply in either local or remote mode.

Fault – Indicates that there is a malfunction in the bar or power supply.

Clean Bar - Indicates that the static bar needs to be cleaned. The “Clean Bar” light on the Power Supply accompanying these instructions is set to illuminate when the bar efficiency falls to 40%. This set point is adjustable in the field, as described above.

Service – Will illuminate when either the ionization is terminated, or there is an electrical restriction that affects the high voltage to the static bar.

Cleaning Instructions

Clean the face of the bar (the surface with emitter points) using a brush with stiff, non-metallic (e.g., nylon) bristles. This will often bring the bar’s efficiency back to or near 100%. If it does not, there may be an accumulation of contamination on the sides or back of the bar. Vigorously clean the sides and back using a brush or cloth and isopropyl alcohol and/or a mild detergent like Dawn dish washing detergent.

Do not re-energize the bar until it is dry.

Dry Contact Connections for Remote Operation

Follow the wiring diagram below for dry contact connections.

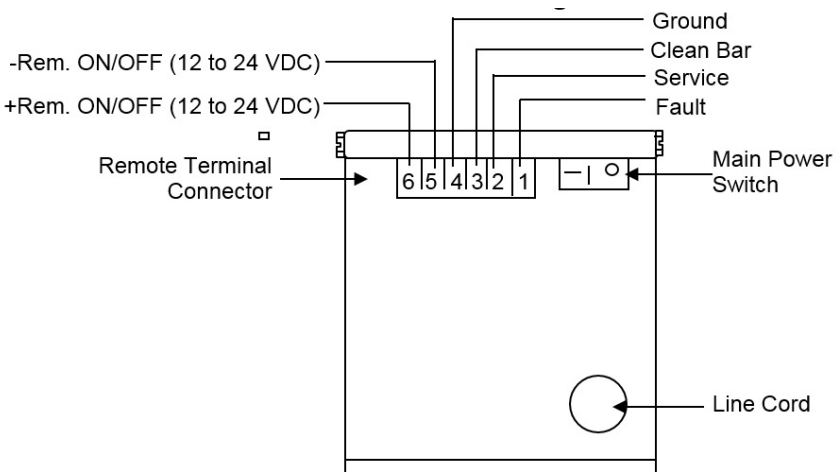

Figure 14. True AC Remote Display Terminal Connection Diagram

6. TROUBLESHOOTING

Qualified service personnel must perform troubleshooting of unit.

“D” Power Supply

Condition	Cause	Solution
No high voltage output	Presence of supply voltage	Replace transformer or bar
	Absence of supply voltage	Check supply voltage and connections

Operating Condition Solutions

Condition	Possible Cause	Solution
No high voltage output	Position of Local/Remote Switch	Make sure the Local/Remote switch is set in the appropriate mode for ON/OFF control
	No supply voltage	Check supply voltage and connection
	Correct supply voltage	Disconnect the bar and reboot power supply by turning main power switch OFF and then back ON. If supply reboots, replace the bar. If the power supply does not reboot, replace the power supply

Indicator Light Solutions

Condition	Possible Cause	Solution
Clean bar indicator will not extinguish during calibration	Bar is mounted too close to web, or ground	Follow bar mounting instructions for R50 Blue Bar
Clean bar indicator will not extinguish after bar is cleaned	Bar is not sufficiently clean.	Re-clean bar
	Sensitivity setting of Clean Bar calibration Something is touching the bar	If new system, re-set calibration. If older system check condition of bar(s) Check the bar mounting to make sure no ground path is contacting the bar
Fault indicator is ON, no output power from supply	HV output short to ground	Disconnect bar, reboot supply by turning main power switch Off then back On, if power supply reboots, replace bar. If supply does not reboot replace power supply

Service Indicator is On.	HV output short to bar sensor return	Disconnect bar and reboot supply, if supply reboots replace the bar
	Short bar sensor return to ground	Make sure all bar connections comply with Figure 13 , and there are no ground connections to the Shield terminal. If all connections are correct, then replace the bar
	HV transformer fails	Replace supply
	Insulative coating on bar	Thoroughly clean the bar to remove any coatings that may be covering points, sides of bar, or back of bar. If condition continues, replace the bar

7. MAINTENANCE

It is recommended that maintenance of R50 Blue Bars be performed every three weeks. Dirty environments may require more frequent cleaning. Maintenance to power supply should be performed every month.



WARNING – Maintenance must be performed by qualified service personnel.

R50 Blue Bar

A cleaning brush with nylon bristles should be used to keep the ionizing pins of the bar clean. Periodic use of the brush will prevent deposits from accumulating on the pins. The ionizing pins must remain sharp for optimum operation.



NOTE – DO NOT SCRAPE PINS WITH ANY HARD OR SHARP OBJECT THAT MAY DAMAGE THE POINTS.



WARNING – Fire Hazard

Do not turn on power supply until all traces of alcohol or mineral spirits are removed.



CAUTION – Electrical Shock Hazard

Turn off power supply before cleaning static bar.

1. Remove dirt particles deposited on the Blue Bar with the cleaning brush or dry compressed air.
2. Remove resistant coatings deposited on the bar by wiping with isopropyl alcohol or mineral spirits applied to a clean cloth.

3. Do not soak bar or related components in alcohol or mineral spirits. Do not use harsh solvents such as lacquer thinner, naphtha or acetone as they will damage the bar housing and epoxy.

Wipe the Blue Bar and supports with a clean dry cloth. Do not apply power to bar until all traces of alcohol or mineral spirits have been removed.

Functionality Check of “N” Power Supplies

The power supply does not require any special maintenance. The user may occasionally check to make certain all ground and electrical connections are clean and tight.

8. REPLACEMENT PARTS

Part	P/N Number
Mounting Kit (contains 2 brackets)	5051063
SLCC HV Connector kit ("D" or TrueAC power supply)	5050001
Strain Relief ("N" power supply)	4612087
Cleaning Brush	4670204

9. WARRANTY

This product has been carefully tested at the factory and is warranted to be free from any defects in materials or workmanship. Simco-Ion will, under this warranty, repair or replace any equipment that proves, upon our examination, to have become defective within one year from the date of purchase.

The equipment being returned under warranty should be shipped by the purchaser to Simco-Ion, 2257 North Penn Road, Hatfield PA 19440, transportation prepaid and insured for its replacement cost. Prior to returning any goods for any reason, contact Simco-Ion Customer Service at (215) 822-6401 for a Return Authorization Number. This number must accompany all returned items.

This warranty does not apply when the equipment has been tampered with, misused, improperly installed, altered, has received damage through abuse, carelessness, accident, connected to improper line voltage, or has been serviced anyone other than an authorized factory representative.

The warranty does not apply when Simco-Ion parts and equipment have been energized by other than the appropriate Simco-Ion power supply or generator, or when a Simco-Ion power supply or generator has been used to energize other than Simco-Ion parts and equipment. Simco-Ion makes no warranty, expressed or implied, nor accepts any obligation, liabilities, or responsibility in connection with the use of this product other than the repair or replacement of parts stated herein.

Simco-Ion

2257 North Penn Road
Hatfield, PA 19440

(215) 822-6401

(800) 203-3419

www.simco-ion.com

customerservice@simco-ion.com

© 2021 Simco-Ion Printed in the U.S.A.