



An ITW Company

MCM 30

Electrostatic Charging Generator

INSTALLATION AND OPERATING INSTRUCTIONS

TABLE OF CONTENTS

1. Notes and Cautions 1

2. Introduction..... 2

3. Specifications 4

4. Installation 5

5. Operation 9

6. Maintenance 11

7. Troubleshooting..... 12

8. Accessories and Parts 13

9. Warranty 13

1. NOTES AND CAUTIONS



NOTE – Statements identified with a NOTE indicate precautions necessary to avoid potential equipment failure.



CAUTION! - Statements identified with a CAUTION indicate potential safety hazards.

NOTE - This equipment must be correctly installed and maintained. Adhere to the following cautions for safe installation and operation:

1. Read the complete Operation / Maintenance Manual before operating. Failure to follow instructions may result in damage to the power unit, MCM 30 Electrostatic Charging Generator and/or personal injury.
2. The AC power adapter is supplied with a 3-prong inlet plug, which must be inserted into an appropriate, properly wired and grounded receptacle outlet.
3. A factory qualified service technician must perform component service and repairs. Please contact Simco-Ion Customer Service for information.



WARNING! – Keep the unit dry. Do not operate the unit in flammable or explosive atmospheres.

Do not make electrical connections to the unit while high voltage is present.

2. INTRODUCTION

The MCM 30 is an adjustable output, DC electrostatic charging generator designed for use with a variety of Simco-Ion charging bars and charging applicators. Using the principles of static charge attraction, the units' high voltage, fixed polarity output provides a method to temporarily pin or bond a variety of materials together. Example uses are stacking, packing, converting, printing plastics, in-mold decoration and other various manufacturing operations.

The compact size of the MCM 30 charging generator makes it well suited for production environments where operating clearances are limited. Because of its low weight and small size, it can be mounted directly to a gantry or robot arm in automated stack pinning processes. The front panel of the power supply features an LED array to provide a continuous indication of the unit's operating condition and level of the adjustable output.

The MCM 30 is powered from 24VDC input. The input voltage is supplied from the provided AC power adapter which is plugged into the terminal block in the end of the unit. The Simco-Ion AC power adapter also supplies the required electrical (machine) ground connection. The input voltage may alternately be supplied to the terminal block from a machine 24VDC power bus located in the parent machinery, however, user supplied 24VDC must provide electrical (machine) ground on the return (negative) side.

The units' terminal block also includes; relay contact connections for indication of when a fault condition has occurred, remote control of output level and remote control of unit on-off.

Features

- Compact size and lightweight.
- Easy installation and operation.
- Adjustable output with visual 10 LED "bar graph" display.
- Mode indicator to indicate voltage or current output display.
- Status indicators to indicate overload, fault, remote program operation, HV output on/off, and power on/off condition.

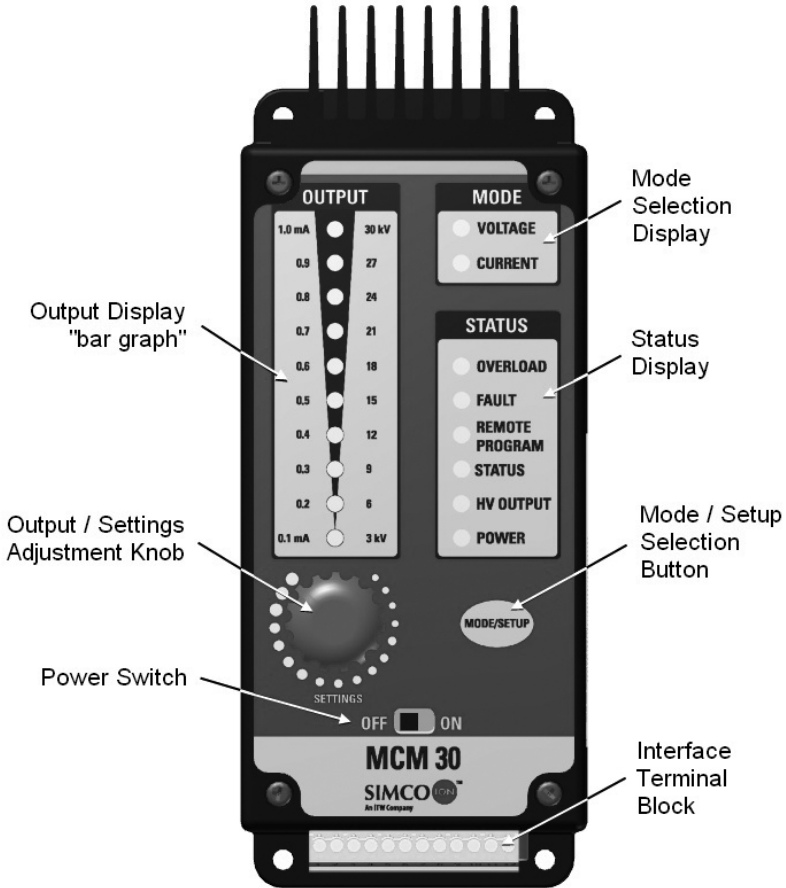

MCM 30 Face View

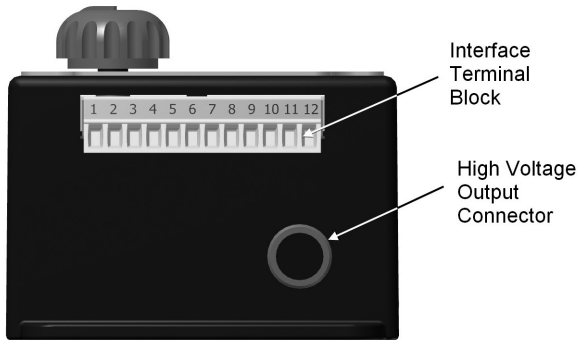

MCM 30 End View

3. SPECIFICATIONS

Input power	24 VDC, 3 A, 75 W (max.)
Output Voltage range	3 to 30 kVDC (negative / positive, depending on unit)
Output Current range	0.1 mA to 1 mA (single output)
Output Connector	SLCC CC-25 (mating plug: Simco-Ion P.N. 4100286)
Charge Applicator	Available from Simco-Ion
Operating Temperature	32°F (0°C) to 104°F (40°C)
ON/OFF Control	Power switch provided on front panel or remote control at terminal block
Output Control	Rotary knob provided on front panel or remote control at terminal block
Indicators	<p>OUTPUT 10 green LED “bar graph” (multi-function, output current and output voltage)</p> <p>MODE: Voltage: green LED Current: green LED</p> <p>STATUS: Overload: red LED Fault: red LED Remote Program: green LED Status: yellow LED HV Output: green LED Power: green LED</p>
Interface Connections	(12) Position terminal block provided at end panel for standard / auxiliary power input, fault alarm output connections and remote control. (Mating plug supplied with unit.) (Reference: mating plug is Phoenix Contact, P.N. 1803675)
Enclosure	ABS plastic (UL94V-0), Color: black
Overall Dimensions	7.75" L x 3.00" W x 2.62" D (197mm L x 76mm W x 67mm D)
Weight	1.7 lb (0.77 kg)
Mounting	Four 0.180" (4.57mm) diameter mounting holes in flanges
AC Adapter (universal)	100-240 VAC, 50-60 Hz input / 24 VDC, 3.75 A output

4. INSTALLATION

Unpacking

Carefully remove the equipment from the carton and inspect the contents.



NOTE - If any damage has occurred during shipment, notify the local carrier at once. A report should also be forwarded to Simco-Ion, 2257 North Penn Road, Hatfield, PA 19440. See Section 9 (Warranty) for Return Shipment information.

Mounting

The MCM 30 charging generator is intended for fixed mounting onto a flat and rigid surface. Holes in the flanges of the unit enclosure are provided for screw mounting to the selected surface. The charging generator enclosure may be used as a template to mark the hole locations onto the surface. The use of #8 or M4 screws, flat washers and nuts are suggested for the final mounting. Because of the many possible mounting situations, screw and nut hardware is not included with the power supply. It is recommended that the unit be positioned so the wiring and charging device cabling exits in a downward direction. This positioning is preferred to minimize stresses that could kink or pinch the wire and cable insulation. Allow for wire and cable flex and support wiring if the installation will be subject to repetitive motion.

Electrical Connections

Connect the charge applicator to the high voltage outlet port using the SLCC (spring loaded cable connector) on the charge applicator. Hand-tighten connector only.



NOTE – Keep high voltage wiring and low voltage wiring separated. DO NOT route high voltage wiring along with low voltage wiring. Intermixing high voltage wiring with low voltage wiring increases the risk of inductively coupled EMI and machine malfunction.



NOTE – Keep high voltage wiring away from sharp edges. Sharp (metal) edges increase risk of high voltage insulation damage due to electric field concentration. Sharp edges may also cause insulation cuts and damage leading to insulation burn-out. Route high voltage wiring away from sharp edges.

Secure the AC adapter in a location suitable for connection to AC line voltage.

Insert the 24 VDC output (+ wire) of the AC adapter or auxiliary power bus into position #1 of the Interface Terminal Block plug and tighten the clamping screw. Insert the Ground (return wire) of the adapter or power bus into position #2 of the Interface Terminal Block plug and tighten the clamping screw. The return wire of the AC adapter is supplied by Simco-Ion is connected to the AC input line ground and this connection must be connected to the local electrical machine ground. Where a machine 24VDC power buss is used, the return wire on Pin 2 must be connected to a local electrical machine ground.

Interface Terminal Block power connections

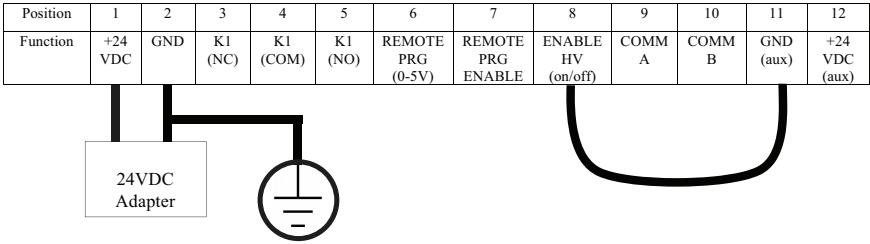

Note that position #8 must be grounded to enable use of on/off switch on face of unit.

Optional Electrical Connections

Interface Terminal Block power connections for remote (PLC) operation

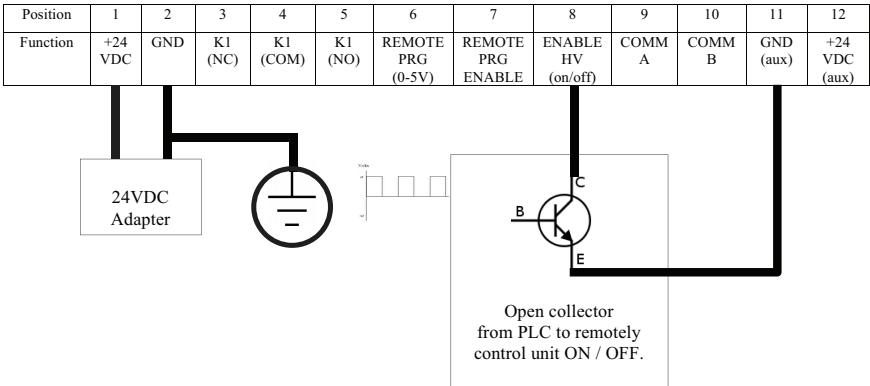

Note that the MCM 30 power switch must be set to "ON" to allow remote control of high voltage output on / off.

Interface Terminal Block position assignments

Position	1	2	3	4	5	6	7	8	9	10	11	12
Function	+24 VDC	GND	K1 (NC)	K1 (COM)	K1 (NO)	REMOTE PRG (0-5V)	REMOTE PRG ENABLE	ENABLE HV (on/off)	COMM A	COMM B	GND (aux)	+24 VDC (aux)

- Position 1** +24 VDC supply must be connected to this position.
- Position 2** GROUND (return) from the +24VDC supply and local electrical machine ground must be connected to this position.
- Position 3** Fault Relay K1 (NC) normally closed, dry contact
- Position 4** Fault Relay K1 (COM) common, dry contact
- Position 5** Fault Relay K1 (NO) normally open, dry contact. The above is with the unit in Fault alarm or with power off. Refer to operation section of this manual for actual function and operation of these contacts.

- Position 6** REMOTE PRG, apply 0 TO +5 VDC to program HV Output in Voltage Mode between 3 kVDC and 30 kVDC.
- The range of voltage to apply may be increased to 0 TO +24 VDC by adding an 62 k Ω (kilohm) ¼ W (watt) resistor in series with the connection to position 6.
- Position 7** REMOTE PRG ENABLE, ground this pin to Pin 11 to program HV Output level using REMOTE PRG input (Pin 6). This pin can be grounded by a PLC with a dry contact switch, an open collector (as shown) or by a FET output. The switching component must be rated for 24VDC @ 10mA. Grounding position 7 will override the programmed mode and set-point. The MCM 30 will switch to Voltage Mode and allow real-time remote adjustment of the HV Output level. Leave position 7 ungrounded, i.e. floating, to adjust the HV Output set-point using front panel rotary Output knob.
- Position 8** Enable HV, ground this pin to Pin 11 to turn on MCM 30 internal power supply, creating HV. Leaving the pin float, i.e. ungrounded, turns off the MCM 30 internal HV power supply. This pin can be grounded by a PLC with a dry contact switch, an open collector (as shown) or by a FET output. The switching component must be rated for 24VDC @ 10mA. Note that the MCM 30 power switch must be set to “ON” to allow remote control of high voltage output on / off.
- Position 9** COMM A, RJ485 communication port. (TX/RX)
- Position 10** COMM B, RJ485 communication port. (TX/RX) Consult Simco-Ion customer service for more information on this option.
- Position 11** GRD (aux) provides a local source of ground for control functions of Pin 6, Pin 7, and Pin 8. GND (aux) also provides a return for Pin 12 (+24VDC (aux)) for external indicator lights, audible alarms, etc.
- Position 12** +24 VDC (aux), supplies a source of power for user convenience to operate low power devices such as indicator lights, audible alarms, etc. Maximum allowable current is 250 mA and should be externally fused to protect the MCM 30.
- (RELAY K1)** (RELAY K1) The fault alarm relay in the MCM 30 is energized under the no-alarm conditions. If there is a power loss to the MCM 30, a fault alarm signal will be generated. The Fault alarm (NO / Pin 5) and (COM / Pin 4) terminals provide contact closure during normal operating conditions; (NC / Pin 3) and (COM / Pin 4) provides contact closure if there is a loss of power to the system or if a fault condition exists, which is indicated by illuminating the Fault LED on the front panel and can be caused by excessive current, overload or a short circuit condition.
- Position 3** K1 Normally Closed (NC) (dry contact)
- Position 4** K1 Common (COM)
- Position 5** K1 Normally Open (No) (dry contact)



NOTE - Fault Relay K1 is of the electro-mechanical type having a DC coil which pulls down an armature which switches the contacts. Contact rating on the relay is 24 VDC, 2 amps. See the following schematic diagram.

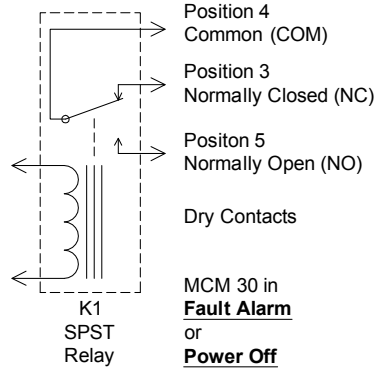
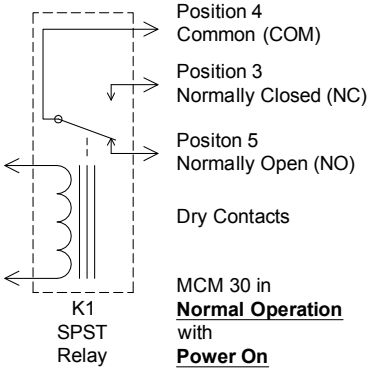

Fault Relay Schematic: example relay operation K1 inside MCM 30



NOTE - Verify that the mounting and connections of the MCM 30 charging generator and charging devices are properly installed prior to turning on the equipment.

5. OPERATION

ON / OFF SWITCH - Switch turns the MCM 30 charging generator on or off. Note that position #8 on the Interface Terminal Block must be grounded (i.e. connected to position #11) to energize the unit using the on/off switch on the face of the unit.

SETTINGS KNOB - Knob controls the output of the High Voltage supply. In the Voltage Mode it provides for output adjustment between 3 and 30 kVDC. In the Current Mode it provides for output adjustment between 0.1 and 1 mA. The Settings knob is also used in conjunction to the MODE/SETUP switch to select voltage or current mode of operation along with the unit address function.

MODE / SETUP – Is a push button tactile switch located on the front panel which toggles the Mode of operation when pressed or is used to enter the Setup sub menus. Pressing this button causes the Status LED to light.

Voltage Mode Function - In Voltage Mode operation, (the Voltage Mode LED will be lit), the MCM30 will display the output voltage on the “bar graph”. Pressing the Mode / Setup button will cause the Current Mode LED to light and the output LED “bar graph” will display the output current. After approximately five (5), the unit will revert to displaying the output voltage.

Current Mode Function - In Current Mode operation, (the Current Mode LED will be lit), the MCM30 will display the output current on the “bar graph”. Pressing the Mode / Setup button will cause the Voltage Mode LED to light and the output LED “bar graph” will display the output voltage. After approximately five (5), the unit will revert to displaying the output current.

Setup Function – To enter the Setup function the MCM 30 needs to be de-energized (Green Power LED is OFF). Then energize the MCM 30, (Green Power LED is lit) and within five (5) seconds press the MODE / SETUP button twice (2) the Status LED will flash each time the button is pressed. Once the MCM 30 is in setup mode either the Voltage or Current LED will be flashing. The Settings knob will be used to select between Voltage or Current Mode control.



NOTE - The MCM 30 will operate in voltage control mode OR current control mode (not both at the same time). In voltage control mode, the unit will adjust output current as needed to maintain the output voltage set-point. In current control mode, the unit will adjust output voltage as needed to maintain the output current set point. If the unit is unable to meet the desired set-point, it will trigger an overload light.

Changing the MODE To change the Mode rotate the knob fully counter clockwise, (CCW) and observe the Mode LEDs, (if you need to change the Mode again rotate the Settings knob clockwise, (CW) at least 45° then fully CCW again.) Once the operating mode is set, (Voltage or Current Mode), then rotate the Settings knob clockwise to set the desired output level on the LED “bar graph” display, (In Voltage Mode the bar graph display represents 3KVDC to 30KVDC and in current mode the bar graph display represents 0.1mA to 1.0mA). To save this setting press the MODE / SETUP button once (the Status LED will flash).

Setting the ADDRESS – Observe the Output LED “bar graph” display and one of the LEDs will be flashing, then rotate the Settings knob fully counter clockwise (CCW) so that the bottom LED, (1.0mA / 3KV), is flashing this is address #1. To change the address rotate the knob CW until the desired Address is set, (1.0mA / 3KV = #1 and 1.0mA / 30KV = #10), each LED represents an address from 1 to 10. To save this setting press the MODE / SETUP button once (the Status LED will flash along with both Mode LED’s and bar graph LEDs lighting indicating that the values have been store in the flash memory).



NOTE – If the MCM 30 is turned off while in setup state, any adjustment to the set-points will be lost. The unit must be placed into the operating state from the setup state for adjustments to the set-points to be recorded.

MODE LEDS - Green LEDs indicate the Mode of operation set on the MCM 30.

Voltage Mode – Where the voltage is fixed to a predefined level and the MCM 30 adjusts the output current automatically.

Current Mode - Where the current is fixed to a predefined level and the MCM 30 adjusts the output voltage automatically until the maximum output voltage of 30KV is reached. If the LED is FLASHING in normal operation this indicated that the MCM 30 is unable to reach the desired current set point and the output voltage is at the MCM 30’s maximum level. This could indicate that the charging applicator requires service or the current level has not been properly set for the charging requirements of the material.

OUTPUT DISPLAY - 10 green LED “bar graph” that indicates voltage or current output in the operating state and voltage or current set-points or Address value in the Setup state.

OVERLOAD - The Red LED illuminates when the output current exceed the maximum current capability of the MCM 30. This is typically due to a short circuit on the HV output, or when the charging applicator exceeds the output current capability of the MCM 30. The Overload LED is a non-latching condition that does not shut off the High Voltage output.

FAULT – Red LED that illuminates when there is a persistent Overload (typically greater than 10 seconds). Fault is a latching condition that shuts off the HV output. To clear a Fault, power (ether power switch or power input) must be cycled off then on.

REMOTE PROGRAM – Green LED that illuminates when Remote Program is Enabled (i.e. position 7 is connected to position 11 on the terminal block.)

STATUS – Yellow LED indicates when the MCM 30 is in setup mode or indicates when the MODE / SETUP button is pressed.

HV OUTPUT – Green LED that illuminates when there is high voltage present on the HV connector.

POWER – Green LED that illuminates when the power switch is on and 24 VDC is applied.

BASIC OPERATION – make all connection per section 4, (Installation) of this manual.

1. Install and mount the charging applicator to the MCM 30.
2. Refer to section 5 (Operation) MODE / SETUP of this manual to select the operating mode and output level.
3. Set the operating Mode, (Voltage or Current), while using the Settings knob adjust the output of the MCM 30 until the desired pinning is achieved.
4. Save this setting to the flash memory per the MODE / SETUP procedure in this manual.
5. The MCM 30 is now ready for service.



NOTE - In setting the output in Current Mode the pinning applicator should be adjusted so as to limit the output voltage to approximately 24KV. This will allow the MCM 30 to automatically adjust the output voltage, (up to 30KV), to compensate for atmospheric changes and contamination.

6. MAINTENANCE

Cleaning



CAUTION! Disconnect the electrostatic charging generator before attempting any cleaning operation.

The exterior surface of the MCM 30 charging generator can be cleaned with a soft cloth moistened with common window cleaning solution. Alcohols or solvent-based cleaners must not be used.



NOTE - The charging generator enclosure is not liquid tight and must not be subjected to aerosol sprays or condensation, as damage to the internal circuitry may occur.

7. TROUBLESHOOTING

This information provides a quick troubleshooting reference for the MCM 30 charging generator. Should any of these possible solutions not solve the problem, please contact Simco-Ion Customer Service.

PROBLEM	POSSIBLE CAUSE	CORRECTIVE ACTION
MCM 30 FAILS TO OPERATE (GREEN INDICATOR OFF)	AC ADAPTER NOT CONNECTED	CHECK ALL ELECTRICAL CONNECTIONS
	AC ADAPTER DEFECTIVE	REPLACE AC ADAPTER
MCM 30 FAILS TO OPERATE CHARGING DEVICE (GREEN INDICATOR ON)	CHARGING DEVICE CONNECTIONS LOOSE	TIGHTEN CHARGING DEVICE CONNECTORS INTO POWER SUPPLY
MCM 30 INDICATES FAULT (RED INDICATOR ON)	CHARGING DEVICE DIRTY OR DEFECTIVE	CLEAN OR REPLACE CHARGING DEVICE
	CHARGING DEVICE SHORTED	CHECK CHARGING DEVICE CLEARANCES

8. ACCESSORIES AND PARTS

<u>Item</u>	<u>Part Number (Negative)</u>	<u>Part Number (Positive)</u>
MCM 30 Unit No AC adapter	4015426	4015427
MCM 30 Unit North America / Japan	4015435	4015438
MCM 30 Unit Continental Europe	4015436	4015439
MCM 30 Unit United Kingdom	4015437	4015440

<u>Item</u>	<u>Part Number</u>
AC Adapter	4110321
Output connector.....	4100286

9. WARRANTY

This product has been carefully tested at the factory and is warranted to be free from any defects in materials or workmanship. Simco-Ion will, under this warranty, repair or replace any equipment that proves, upon our examination, to have become defective within one year from the date of purchase.

The equipment being returned under warranty should be shipped by the purchaser to Simco-Ion, 2257 North Penn Road, Hatfield PA 19440, transportation prepaid and insured for its replacement cost. Prior to returning any goods for any reason, contact Simco-Ion Customer Service at (215) 822-6401 for a Return Authorization Number. This number must accompany all returned items.

This warranty does not apply when the equipment has been tampered with, misused, improperly installed, altered, has received damage through abuse, carelessness, accident, connected to improper line voltage, or has been serviced anyone other than an authorized factory representative.

The warranty does not apply when Simco-Ion parts and equipment have been energized by other than the appropriate Simco-Ion electrostatic charging generator or generator, or when a Simco-Ion electrostatic charging generator or generator has been used to energize other than Simco-Ion parts and equipment. Simco-Ion makes no warranty, expressed or implied, nor accepts any obligation, liabilities, or responsibility in connection with the use of this product other than the repair or replacement of parts stated herein.

Simco-Ion

2257 North Penn Road
Hatfield, PA 19440

(215) 822-6401
(800) 203-3419
www.Simco-Ion.com
customerservice@Simco-Ion.com

© 2011 Simco-Ion. Printed in the U.S.A.