



An ITW Company

# **Pinner™ Series Arc Resistant Pinner Applicators**

---

## **INSTALLATION AND OPERATING INSTRUCTIONS**

# TABLE OF CONTENTS

---

<b>1. SAFETY</b> .....	<b>3</b>
<b>2. INTRODUCTION</b> .....	<b>3</b>
Features and Benefits .....	3
How Pinners Work .....	4
Receipt of Equipment.....	4
Return Shipments.....	4
<b>3. SPECIFICATIONS</b> .....	<b>5</b>
<b>4. INSTALLATION</b> .....	<b>5</b>
Standard Installation.....	5
Installation with Optional Mounting Stand (P/N 5051082) .....	6
High Voltage Wire Routing.....	6
<b>5. OPERATION</b> .....	<b>8</b>
<b>6. MAINTENANCE</b> .....	<b>8</b>
<b>7. TROUBLESHOOTING</b> .....	<b>8</b>
<b>8. REPLACEMENT PARTS</b> .....	<b>9</b>
<b>9. WARRANTY</b> .....	<b>9</b>

## 1. SAFETY

---



**NOTE** – Statements identified with a NOTE indicate precautions necessary to avoid potential equipment failure.



**CAUTION** – Statements identified with a CAUTION indicate potential safety hazards.

The following safety procedures must be followed for safe Pinner operation.

1. Read instruction manual before operating or installing device.
2. Qualified service personnel must do installation and repairs.
3. Turn off power supply before cleaning, adjusting or servicing the Pinner applicator.
4. Do not install or operate Pinner applicators close to flammable materials, solvents or gases. These materials may ignite.
5. Do not touch the head of the Pinner applicator during operation.
6. All metal parts near the Pinner applicator, including the frame of which it is mounted, must be electronically grounded or shock may result.
7. Provide proper grounding for the power supply (refer to power supply instruction manual) and the flex arm, if used.

## 2. INTRODUCTION

---

Simco-Ion's Pinner Series static charge applicators consists of the Linear Pinner, 5-Point and Pinner Claw. Pinner applicators are arc-resistant to avoid suspension of static charge and loss of pinning action. The Pinner are current limited to ensure operator and equipment safety.

Arcing can cause a multitude of problems such as EMI interference, shutdown of production lines and personnel injury due to surprise from electrical shock. Resistance to arcing means that the Pinner applicators continuously supply static charge. This feature makes them easier and safer to set up and use. The Pinner also produces superior bonding compared to less sophisticated applicators. The applicators are also available in a non-current limited version for less sensitive areas.

### Features and Benefits

- Current limited design for operator and equipment protection
- Arc condition sensing and instantaneous intervention resulting in uninterrupted pinning action
- Minimized EMI and RFI generation, preventing disruption of sensitive controls
- Optional manual adjust gooseneck with easy lock/release feature and insulative brackets

- Rated for use in temperatures to 500°F
- Designed and tested as an integral component of Simco-Ion electrostatic charging systems

### **How Pinners Work**

Simco-Ion's electrostatic charging power supplies provide high voltage to the Linear Pinner, 5-Point and Pinner Claw points. The electrical stress at the points produce corona which injects ions into the air. These ions are attracted to surfaces at ground potential. Materials placed between the high voltage points and ground will become electrostatically charged and adhere to each other or to ground, depending upon the setup.

### **Receipt of Equipment**

1. Carefully remove the equipment from the carton.
2. Inspect contents for damage that may have occurred during shipment. If any damage has occurred during shipment, the local carrier should be notified at once. A report should be forwarded to Simco-Ion, 2257 North Penn Road, Hatfield PA 19440, and (215) 822-6401.
3. Empty the carton to insure that small parts are not discarded.

### **Return Shipments**

Prior to returning goods, contact a Simco-Ion Customer Service representative for a Return Authorization Number. This number should be included on the packing list. All correspondence should also reference the Return Authorization Number. Any item being returned should be shipped prepaid and packed to provide adequate protection.

### 3. SPECIFICATIONS

<b>Dimensions</b>	Linear	<u>Overall Length</u>	<u>Handle Diameter</u>
	5-Point	4.75"	.75
	Claw	6.75"	.75
<b>Charge Pattern</b>	Linear Pinner and Pinner Claw: 0.5" x 2.5" to 1" x 5" elliptical; 5-Point: 1" x 2" circular pattern		
<b>Ion Output Current at 0.5" from Ground</b>	(kV)	<u>5-Point (µA)</u>	<u>Claw (µA)</u>
	20	73	80
	25	91	100
	30	110	120
	50	183	200
<b>Operating Voltage</b>	±30 kV max; ±50 kV in special installation with insulation required (minimum 3" space clearance from all non-insulated ground sources)		
<b>Cable</b>	10' standard length		
<b>Mounting</b>	Standard: Insulative brackets with fastening hardware Optional: Manual adjust gooseneck with easy lock/release feature		
<b>Operating Distance</b>	30 kV - 0.5" min; 50 kV - 1" min		
<b>Current Limit</b>	30 kV input - 375 µA; 50 kV input - 625 µA		
<b>Short Circuit</b>	Pin to Ground at 30 kV Input, Non-Repetitive: 2-second maximum, no damage		
<b>Weight</b>	0.65 lbs		

### 4. INSTALLATION



**NOTE** – To install pins into Pinner Claw:

1. Push blunt end of pin into head's socket
2. Rotate pins until desired ion pattern is produced

#### Standard Installation

Two mounting clamps and hardware are standard with each Pinner applicator. The mounting clamps are made of insulative material to prevent voltage breakdown of the applicators.

Before attaching the applicator to the mounting clamp, insert the shrink tubing supplied with the mounting kit, over the round handle of the applicator. The shrink tubing ensures that the applicator is firmly attached to the mounting clamp. The tubing is not required when mounting the applicator to the optional FlexArm stand. Shrink tubing is required for each mounting clamp.

You can install the Pinner applicator to the mounting surface using the perforated strip supplied (see Figure 1) or using the mounting plate assembly (P/N 4105581, see Figure 2).



**NOTE** – The mounting clamps for the 5-Point and the Pinner Claw must be at least 2” apart. Closer installation may cause warping of the Pinner handle at temperatures exceeding 150°F.

The two mounting clamps for the Linear Pinner can be installed side by side

Make sure the threaded end of each screw is flush with the inside surface of the clamp to maintain the installation distance (air space) to the Pinner shaft. Screws provided are the proper length for mounting the clamps to the assembly (1/4 - 20PHM, 5/8” long). Use screws supplied with flex arm mounting stand when using this option.

### **Installation with Optional Mounting Stand (P/N 5051082)**

The optional mounting stand includes a flexible adjustable arm and a magnetic base. It is designed for use in areas where flexibility, easy adjustment, or easy installation and removal is required, such as chill roll edge pinning on cast film lines.

Refer to publication 5101223 (attached with optional mounting stand kit) and Figure 4 for additional assembly details.

1. Remove two cap screws with 3/16” hex key and magnet from base of mounting stand.
2. Remove cable strain relief from base of mounting stand.
3. Insert pinner applicator (Linear Pinner, Pinner 5-Point or Pinner Claw) by fully straightening the flexible arm and routing the cable assembly through its center and cable strain relief.
4. Insert pinner applicator handle fully into the mounting barrel and tighten the setscrew.
5. Bend the flexible arm into a tight U-shape and screw the cable strain relief into the base of mounting stand.
6. Tighten the strain relief nut to securely clamp the cable assembly in place.
7. Re-install the magnet on to the base of mounting stand.
8. Position the pinner applicator by attaching the magnetic base of the mounting stand in a suitable location.
9. Adjust the flexible arm of the mounting stand to direct the pinner applicator towards the targeted object.

### **High Voltage Wire Routing**

To avoid accidental shock, route the high voltage wire to the power supply in a manner which avoids access or contact by personnel. Do not route through areas where moving machinery is operating. Secure the wire with TW wraps or cable clamps to assure proper and permanent positioning.



**NOTE** – Pinner 5-point, Linear Pinner and Pinner Claw products are rated for use with up to 30kV or  $\pm 50\text{kV}$  in special installations with insulation required. Use at high voltages may cause component breakdown and operator shock hazard.

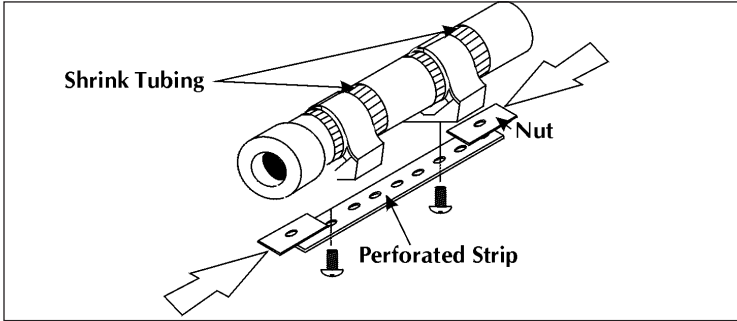

Figure 1. Mounting Using Perforated Strips

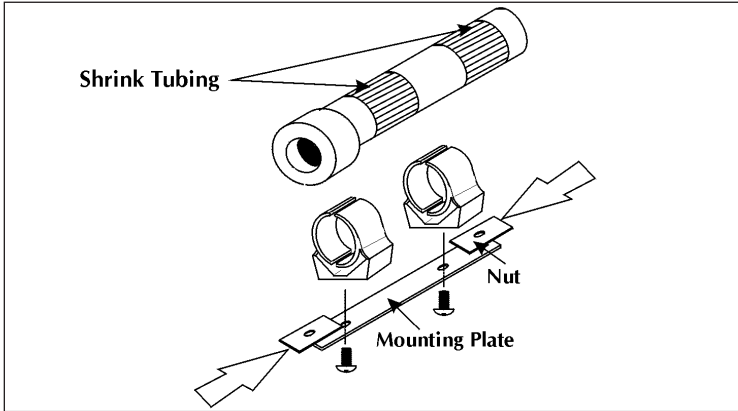

Figure 2. Mounting Using Plate

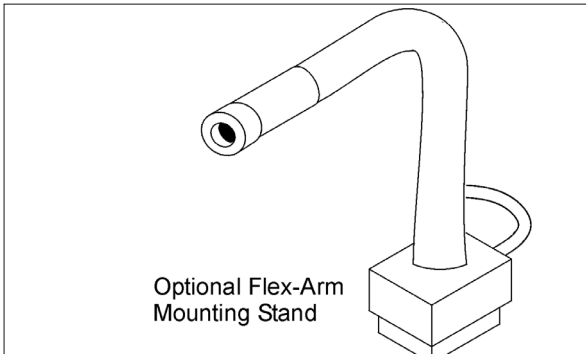

Figure 3. Mounting Using Plate

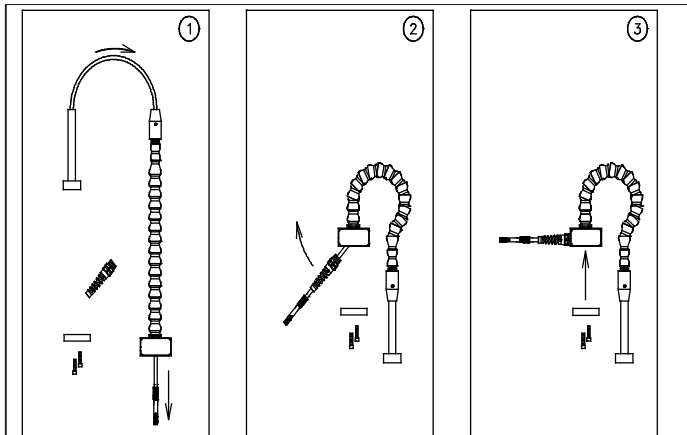

Figure 4. Assembly details of Pinner Applicator on Mounting Stand

## 5. OPERATION

---

Simco-Ion's Power Supplies provide high voltage to the Pinner 5-Point, Linear Pinner and the Pinner Claw. The electrical stress at the points produces corona, which injects ions into the air. These ions are attracted to surfaces at ground potential. Materials placed between the high voltage points and ground will become electrostatically charged and adhere to each other or to ground, depending upon setup.

Pinner applicators are designed for use where:

- EMI/RFI affects sensitive controllers
- Loss of pinning action is detrimental to the product or operation
- Operators may come into contact with materials

## 6. MAINTENANCE

---

Pinner applicators require simple maintenance procedures. Clean the applicators periodically with isopropyl alcohol. Use a cleaning brush (P/N 4670204) as needed to keep the pins free of contaminants.

Pinner Claw emitters may be replaced if they become worn (see the installation and the replacement parts sections of this manual).

## 7. TROUBLESHOOTING

---

If the unit fails to operate properly, please call your Simco-Ion representative.



## 8. REPLACEMENT PARTS

---

Part	Part Number
Linear Pinner applicator	4009903
Pinner Claw applicator	4008144
5-Point applicator	4004738
Flex Arm mounting assembly	5051082
Mounting plate assembly	4105581
Teflon head and radial pin assembly	5050470
Spring loaded cable connector	4100286
Stainless jumper plug	4640763
Replacement resistor	4590820
Additional HV wire, custom length	4810276
Cleaning brush	4670204
Claw pins replacement kit	5050919

## 9. WARRANTY

---

This product has been carefully tested at the factory and is warranted to be free from any defects in materials or workmanship. Simco-Ion will, under this warranty, repair or replace any equipment that proves, upon our examination, to have become defective within one year from the date of purchase.

The equipment being returned under warranty should be shipped by the purchaser to Simco-Ion, 2257 North Penn Road, Hatfield PA 19440, transportation prepaid and insured for its replacement cost. Prior to returning any goods for any reason, contact Simco-Ion Customer Service at (215) 822-6401 for a Return Authorization Number. This number must accompany all returned items.

This warranty does not apply when the equipment has been tampered with, misused, improperly installed, altered, has received damage through abuse, carelessness, accident, connected to improper line voltage, or has been serviced anyone other than an authorized factory representative.

The warranty does not apply when Simco-Ion parts and equipment have been energized by other than the appropriate Simco-Ion power supply or generator, or when a Simco-Ion power supply or generator has been used to energize other than Simco-Ion parts and equipment. Simco-Ion makes no warranty, expressed or implied, nor accepts any obligation, liabilities, or responsibility in connection with the use of this product other than the repair or replacement of parts stated herein.

**Simco-Ion**

2257 North Penn Road  
Hatfield, PA 19440

(215) 822-6401

(800) 203-3419

[www.simco-ion.com](http://www.simco-ion.com)

[customerservice@simco-ion.com](mailto:customerservice@simco-ion.com)

© 2021 Simco-Ion. Printed in the U.S.A.