



Magnum Force™ Air Knife & Nozzle

INSTALLATION AND OPERATING INSTRUCTIONS

TABLE OF CONTENTS

1. SAFETY WARNINGS	1
2. DESCRIPTION	2
Return Shipments.....	3
3. SPECIFICATIONS	4
4. INSTALLATION.....	6
Air Knife/Static Bar Positioning and Mechanical Requirements	6
Switching Static Bar Position	6
Switching Static Bar High Voltage Lead Location.....	7
For Magnum Force Equipped with the MEB or R50 Static Bars.....	7
For Magnum Force Equipped with the IQ Power Static Bar	7
Blower/Ducting Installation	7
Connecting Shockless Static Bar MEB with F167/F267, D167/D267 Power Supplies.....	8
Connecting R50 Bar with D167/D267 Power Supply.....	9
Connecting IQ Power BPS Power Supply.....	9
5. OPERATION	10
Initial System Testing.....	10
Subsequent System Operation	10
6. TROUBLESHOOTING.....	11
Power Supply Testing.....	11
Static Bar Checking	11
Blower and Ducting	11
7. MAINTENANCE	12
8. PARTS AND ACCESSORIES.....	13
9. WARRANTY	14

1. SAFETY WARNINGS

PLEASE READ INSTRUCTIONS COMPLETELY BEFORE STARTING INSTALLATION.

ALL INSTALLATION AND TROUBLESHOOTING OPERATIONS MUST BE PERFORMED BY QUALIFIED TECHNICAL PERSONNEL.

This instruction manual uses symbols to identify dangerous situations as follows:



NOTE – Statements identified with NOTE indicate precautions necessary to avoid potential equipment failure.



CAUTION – Statements identified with CAUTION indicate potential safety hazards.



WARNING – Statements identified with WARNING indicate potential serious injury hazards.



NOTE – This equipment must be correctly installed and properly maintained. Adhere to the following notes for safe installation and operation:

1. Read instruction manual before installing or operating equipment.
2. Only qualified service personnel are to perform installation and repairs.
3. All equipment must be properly grounded, including the machine frame to which the equipment is mounted.
4. Turn off input power to unit before connecting or disconnecting other equipment.
5. Do not use standard Ethernet cables with IQ Power Systems.



NOTE – Do not attempt to operate at voltages other than those specified.



NOTE – Do not allow dust, dirt or debris to block or obstruct air flow inlets or outlets.



WARNING – Electrical Shock Hazard

Electrical installation and repairs must be performed by a skilled electrical engineer according to the applicable national and local regulations. The equipment must be properly grounded. Grounding is required to ensure safe and proper operation and to prevent electrical shocks upon contact.

2. DESCRIPTION

The Magnum Force™ System eliminates static and removes particulate from flat and contoured surfaces by combining a static neutralizing bar with a high penetration air knife. Air for the air knife is supplied by a mid-to-high velocity blower.

Magnum Force's shockless static bar delivers positive and negative ions to the surface via the air flow from the air knife. If the object has a positive charge, it will draw negative ions from the air flow. If the object has a negative static charge, it will draw positive ions from the air flow. The rich supply of both positive and negative ions ensures that regardless of polarity, the object will be neutralized.

The Magnum Force can be equipped with an MEB, IQ Power, or R50 static bar. The MEB shockless static bar is used in normal applications. IQ Power static bars are normally for air knives over 100". The R50 shockless static bar is used when a high charge is present on the material's surface.

Particulate being held in place by a static charge is removed by the high velocity, ionized air flow from the Magnum Force. By opening and closing the air knife's vanes, the precise volume and velocity of air needed to remove the particulate is delivered.

The Magnum Force's blower provides the correct supply of air for your system. The blower gives energy to the air at a lower, more efficient, pressure than a high pressure compressor. An inlet muffler is installed to control noise level.

The Magnum Force comes in many different horse powers and sizes at 1800 RPM and 3600 RPM. The 1800 RPM series of blowers are ideal when light particulate and ionizing are required. Another benefit of the 1800 RPM blower is that the noise level is at 78 to 82 decibels while the 3600 RPM blower produces between 89 to 112 decibels. When heavier particulate or dust removal is necessary, 3600 RPM high power, mid velocity or high power, high velocity blowers are best suited. The high power blowers provide higher pressure and more volume at the blade of the air knife giving the air more energy to clean an object.

The Magnum Force System has many benefits.

- High penetration air knives are used on liquid blow-off
- Removal of the static charge allows particulate to be removed more effectively
- High performance air knives clean more efficiently
- Low-pressure blowers allow the job to be done less expensively

The static bar has sharp emitter points that emit positive and negative ions. The ions are delivered by the air-flow to the surface to be cleaned. (see Figure 1).

The air knife is designed to provide a precise, continuous flow of high velocity air. Scientifically designed curved blades direct the air-flow out of the knife and onto the surface to be cleaned.

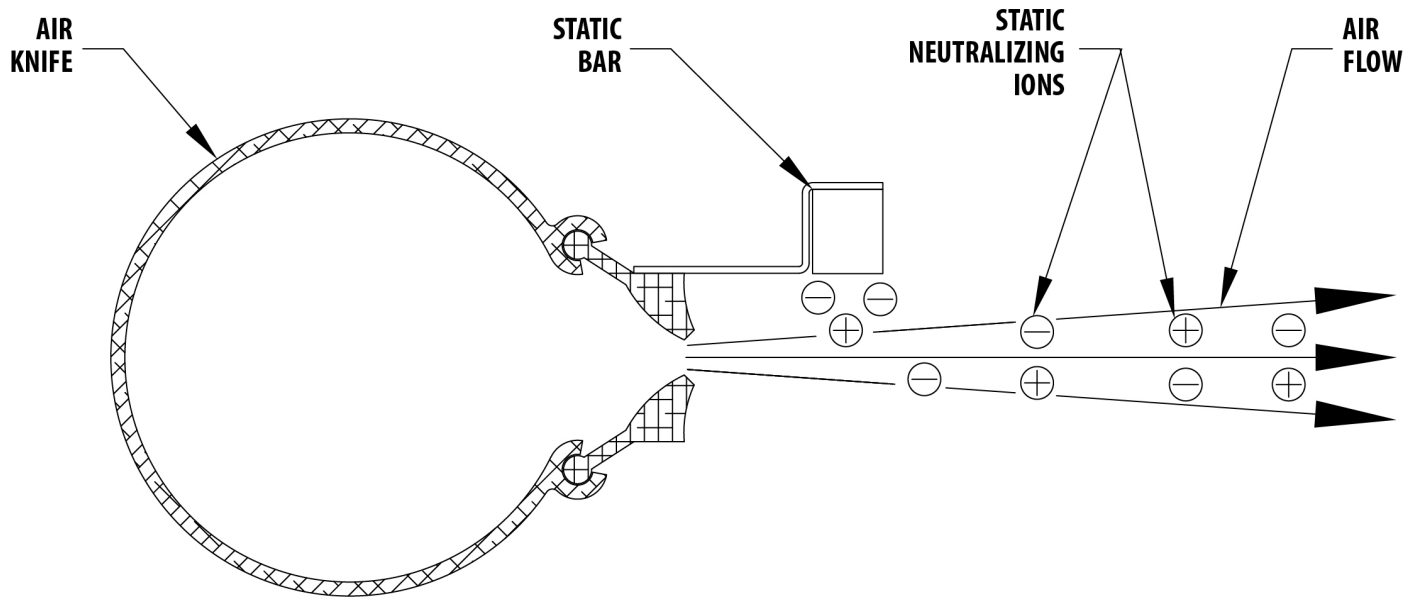

Figure 1. Magnum Force Cutaway Shot

Return Shipments

Prior to returning equipment, contact Simco-Ion Customer Service for a Return Authorization Number. This number should be included on the packing list. All correspondence should also reference the Return Authorization Number. Any item being returned should be shipped prepaid and packed to provide adequate protection.

3. SPECIFICATIONS

R50 Static Bar (see Figure 2): Shockless; glass reinforced polyester; emitter pins current limited; housing filled with polyurethane.

MEB Static Bar (see Figure 2): Shockless, extruded aluminum housing; anodized finish; PVC inner housing; 302 stainless steel emitter points.

IQ Power Static Bar (see Figure 2): Shockless; glass reinforced polyester; tungsten current limited emitter pins.

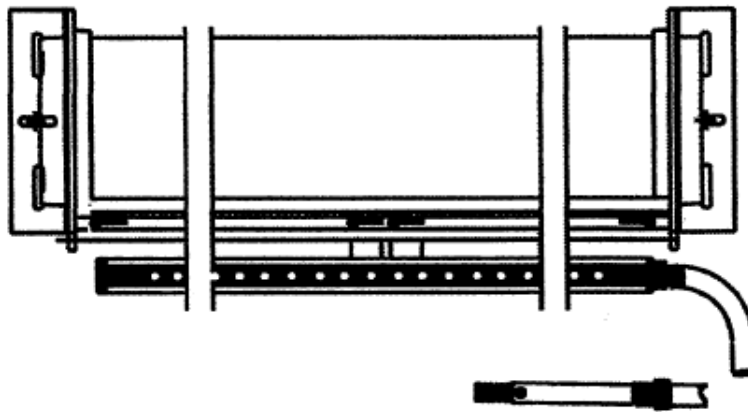

Figure 2. Magnum Force with Air Knife

Power Supply F167/F267, N167/N267 (MEB & R50 Static Bars)	
Input Voltage	120V, 60 Hz
Certification	UL Listed, CSA, CE
IQ Power BPS (IQ Power Static Bars)	
Power	AC Adaptor or IQ Power Control Station
Certification	UL Listed, cUL, CE
Blower	
Power	208-230V or 460V; 60 Hz; 3 phase; totally enclosed fan-cooled motor (TEFC); Fan size varies to fit application; 380 and 575 volts and 50 Hz versions available.
Audible Noise	<78 dB @ 3' to 100 dB
Silencer/Filter	10-micron replaceable cartridge in coated steel casing; includes ANSI 125/150 flange blower intake connection and hardware
Enclosure	Reinforced fiberglass housing and cast aluminum wheel with powder coated steel motor base
Weight	Varies according to blower and motor combination

Air Knife	
Length	Standard Unit: 4" dia. – 18-60" and 6" dia. – 60-120" Standard inch increments; custom sizes available
Air Velocity	5,000 to 20,000 fpm; specification certified by air movement and control association (AMCA); output orifice factory set to 0.125" adjustable from 0.32-0.25"
Air Inlet	Air Knife supplied standard with single end, both ends, center or double top
Mounting	Stainless steel, flanged support collars and hardware
Enclosure	Extruded aluminum with cast aluminum flanged end collars; anodized for corrosion protection; powder-coated cast aluminum ends and center inlet collars
Weight	Varies according to length

4. INSTALLATION

Air Knife/Static Bar Positioning and Mechanical Requirements

1. The Magnum force should be permanently mounted. For best results, angle the air 5 to 10 degrees toward leading edge of conveyor/web direction. Place the air knife opening as close to the surface as possible allowing neutralization to occur more quickly.
2. Mount the Magnum Force air knife's mounting bracket to a machine frame or similar rigid structure using the four inch long ¼ - 20 hex head machine screws, nuts and washers included. You may want to place the Magnum Force in position, mark the mounting surface and drill and tap the surface.
3. Attach the Magnum Force by screwing one mounting screw through the ground lead ¼" lug and bracket right into the mounting surface. Then screw the remaining mounting screws through the bracket and into the mounting surface.



WARNING – Personal harm and machine damage – carefully examine the structure you are drilling and tapping. Make sure the structure is not a fluid carrying pipe, tank, electrical box or similar device or structure.

Switching Static Bar Position

If necessary, switch the position of your static bar to place it upstream of the air knife (see Figure 3).

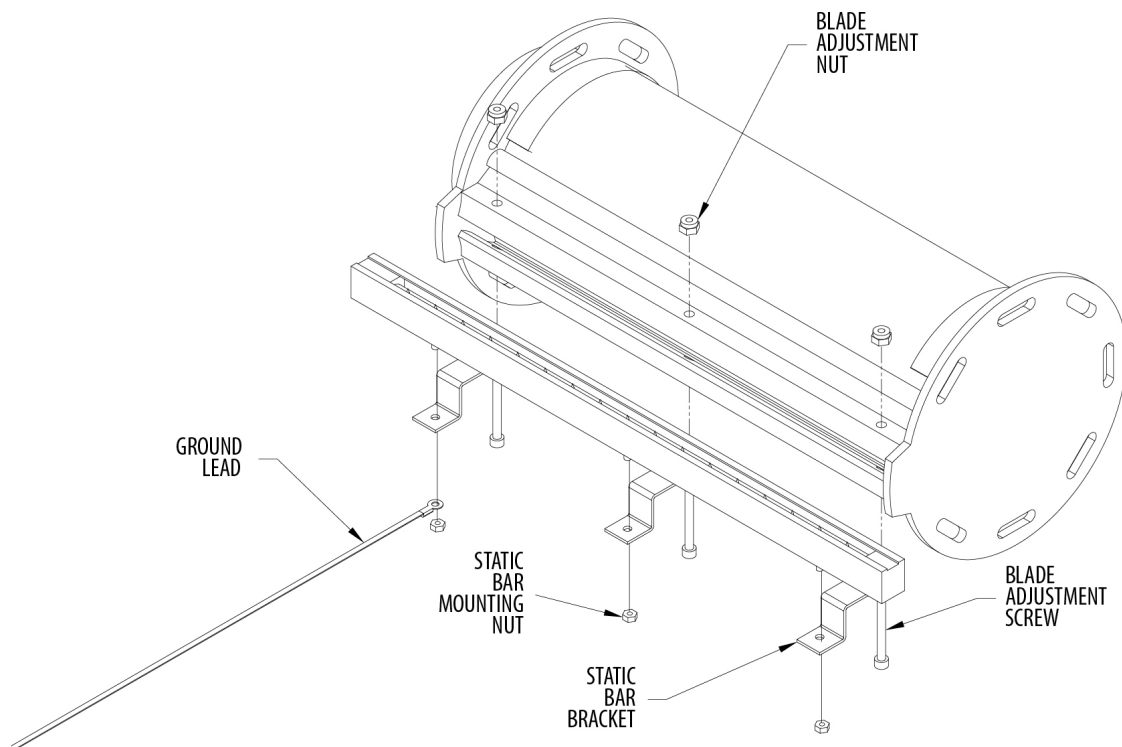

Figure 3. Switching Static Bar Position

1. Place the knife on a work surface with the adjustment blades facing front.
2. Remove the blade adjustment nuts from the blade adjustment screws.
3. Remove the static bar and brackets.
4. Look between the air knife blades. Notice there are springs on every screw to separate the blades (called blade separator springs).
5. Remove the blade adjustment screws and collect the blade separator springs.
6. Place the static bar and brackets on the upstream side of the air knife.
7. Align the holes in the brackets with holes in the air knife blade.
8. Insert the blade adjustment screws through the holes in the brackets and the holes in the upstream air knife blade. Do not insert the screws through the other blade.
9. Put a blade separator spring on each blade adjustment screw.
10. Push the blade adjustment screws through the holes in the downstream blade.
11. Place a blade adjustment nut on every blade adjustment screw.
12. Close the blade opening to 1/8".

Switching Static Bar High Voltage Lead Location

If necessary, switch the position of your static bar so the high voltage lead comes out the opposite side.

For Magnum Force Equipped with the MEB or R50 Static Bars

1. Remove static bar from brackets holding it to the air knife by loosening nuts or screws. Pull bar out of holes in brackets.
2. Position static bar so high voltage lead comes out opposite side.
3. Align static bar with holes on the brackets. Reinsert nuts or screws thru brackets and bar.
4. Make sure emitter pins are pointing at the air stream slot.

For Magnum Force Equipped with the IQ Power Static Bar

1. Remove static bar from brackets holding it to the air knife by loosening set screws. Slide bar out of holes in bracket.
2. Rotate bar into position.
3. Slide static bar back through brackets. Insure brackets are not covering holes and emitter pins. Placing the brackets over the holes or too close to emitter pins could lead to early failure of the static bar.
4. Make sure emitter pins are pointing at air stream slot.
5. Tighten set screws.

Blower/Ducting Installation

Locate the low pressure, high-volume blower as close to the Magnum Force air knife as possible. Performance decreases when the blower is placed far from the air knife. Mount the blower to a secure permanent surface. If the unit is not mounted securely, the vibration of the unit may cause it to "walk" around.

Connect the blower to the air knife with ducting (see Figure 4)

1. Run ducting from blower to Magnum Force air knife.
2. Use enclosed hose clamps to attach flexible tubing to blower and air knife. Do not place blast gate in system before testing. Simco-Ion sizes system to supply correct amount of airflow. The blast gate can be installed later if you find air flow from air knife excessive.

If you are supplying ducting in addition to supplied flexible tubing, place one foot of flexible tubing between air knife and ridged tubing for installation of blast gate in the line if needed.

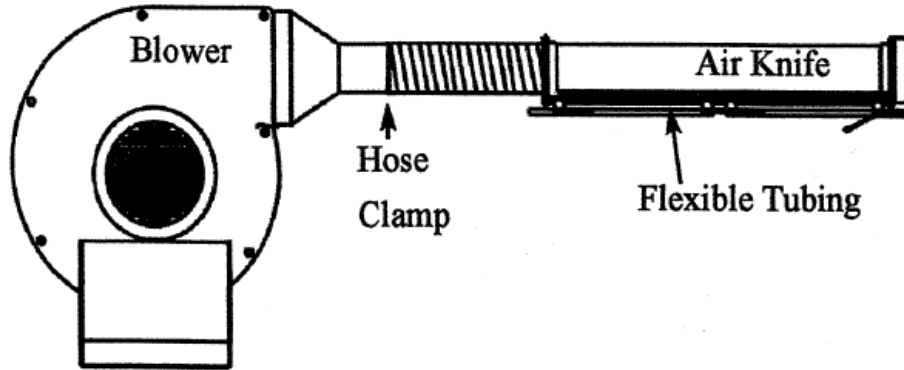

Figure 4. Blower/Ducting Installation

Connecting Shockless Static Bar MEB with F167/F267, D167/D267 Power Supplies

1. Use pattern in Figure 6 for mounting power supply on your machine. Mount power supply following instructions included with power supply.
2. Install spring loaded cable connector to static bar's high voltage cable. See power supply instructions for procedure.
3. Connect high voltage cable to power supply following power supply instructions.

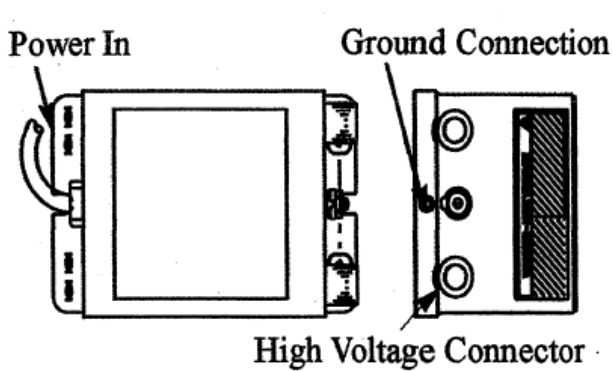

Figure 5. F167/F267, D167/D267 Power Supplies

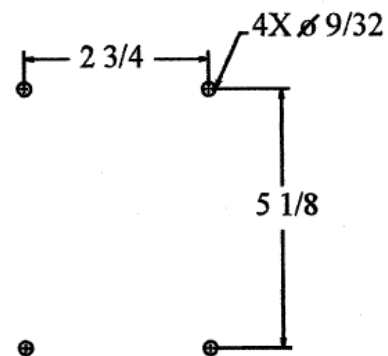

Figure 6. F167/F267, D167/D267 Mounting Pattern

Connecting R50 Bar with D167/D267 Power Supply

1. Use pattern in Figure 7 for mounting power supply on your machine. Mount power supply following instructions included with power supply.
2. Install spring loaded cable connector to static bar's high voltage cable. See power supply instructions for procedure.
3. Connect high voltage cable to power supply following power supply instructions.

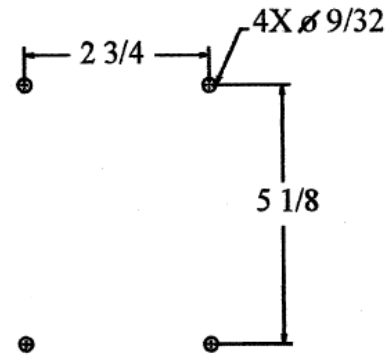

Figure 7. D167/D267 Mounting Pattern

Connecting IQ Power BPS Power Supply

1. Use pattern in Figure 8 for mounting power supply on your machine. Mount power supply following instructions included with your power supply.
2. Route conduit from static bar to power supply following instructions included with power supply.
3. Connect high voltage cable following instructions included with power supply.

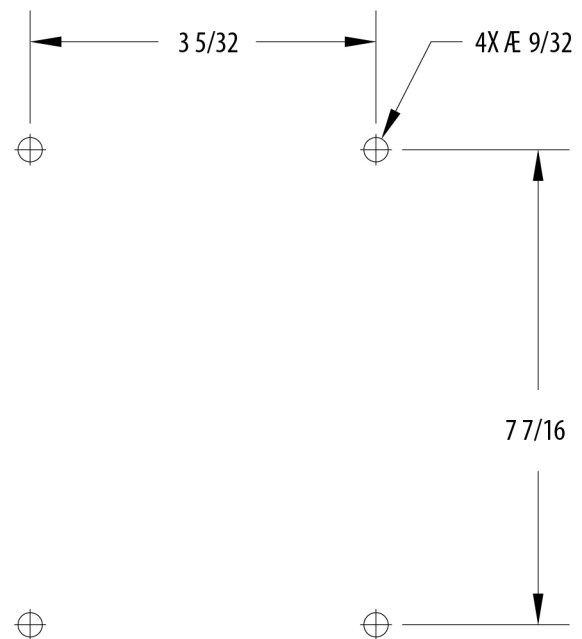

Figure 8. IQ Power BPS Mounting Pattern

5. OPERATION

Initial System Testing

After all the components are set up, the system must be adjusted to the correct operating level. Turn on the blower and check that the air stream is sufficient and even.

If the airflow is heavier at one end than the other, reduce the air opening. The factory setting is 1/8", which should be satisfactory for your application.

If air velocity is too low:

- Be sure airway is not clogged with foreign material
- Be sure blast gate or other valves in system are fully open
- Start opening slot gap. This will increase air flow velocity and CFM
- Check all other air knives, if they are using too much air, they may be starving a particular knife
- Be sure all slot openings are set to 1/8" for proper system performance
- Be sure amperage rating to your blower does not exceed name plate value

If air velocity is too high:

- Slowly close blast gate opening to achieve required air flow
- Start closing slot gap. This will decrease air flow velocity and CFM
- Be sure amperage rating to your blower does not exceed name plate value

Subsequent System Operation

Simco-Ion's Magnum force ionizing air knife system can be run after initial system testing. Follow the recommendations in the Maintenance section to ensure continuous carefree operation.

If a problem is still evident, contact your Simco-Ion representative or Simco-Ion Customer Service.

6. TROUBLESHOOTING

Simco-Ion's Magnum Force ionizing air knife system should be trouble free as long as a regular maintenance schedule is followed and the system is not damaged. However, if performance is reduced or poor, check the following:

Power Supply Testing

See power supply instructions.

Static Bar Checking



WARNING – Electrical Shock Hazard

High voltage present – refer testing to qualified service personnel.

The high voltage power supply must be on to test the static bar. When equipment fails to function properly, check connections to be sure they are tight before proceeding with the following tests.

Determine if the static bar is functioning properly using a Simco-Ion Static Bar Checker to test each point on the bar. Contact our Simco-Ion representative or contact Simco-Ion Customer Service for details on obtaining a Static Bar Checker.

Check each point on the bar following the static bar checker instructions.

Once it is determined that the power supply is operative, locate faulty bar(s) by performing the following;



NOTE – Disconnect power supply during disconnection and reconnection of static bars.

1. Disconnect all but one static bar from high voltage terminal.
2. Use Static Bar Checker to test several points on bar. If red glow occurs, disconnect that bar, reconnect next bar. Check all bars until faulty bar(s) is located.

Blower and Ducting

1. Secure power to blower
2. Remove blower and check filter on inlet to blower. If it is dirty, replace it. The replacement filter part number should be on the nameplate.
3. Check flexible tubing and make sure it does not have a hole or is crushed. If hose is damaged, replace it. The flex hose part number is listed in the Replacement Parts section of this manual.
4. Check hose clamps are secure and air is not leaking at connections.

7. MAINTENANCE



WARNING – Electrical Shock Hazard

Turn off any equipment near the Magnum Force before performing maintenance.

Always turn off current to high voltage power supply before any work is done on equipment unless instructions state otherwise.

Weekly

- Examine exhaust slot of knife for even flow of air
- Verify slot opening did not change
- Examine hardware for security
- Check that blower filter is clean. If filter is dirty, replace it

Monthly

- Check exhaust slot and remove any obstructions



NOTE – Through the exhaust slot there are adjustment screws to maintain the slot spacing. **DO NOT** remove these.

- Clean static bar ionizing points using a brush with non-metallic bristles.
- Wipe down exposed surfaces. Use compressed air to remove debris from non-exposed surfaces.

As Needed or Yearly

- Clean ionizing points to remove built up deposits by pressing an abrasive pencil eraser on each ionizing point and twist slowly.

Safety

Observe all safety precautions when installing this product.

- Ensure primary voltage and frequency are in compliance with that listed on equipment before applying power
- Power supply, blower and static bar must be grounded for proper and safe operation
- Do not operate unit with loose, missing or damaged parts
- Do not attempt to operate high voltage power supply or blower at voltages other than specified on the name plate
- Keep units clean and dry
- Do not allow dust, dirt and debris to block or obstruct air flow inlets or outlets
- Do not operate blower, non-explosion proof power supply or non-explosion proof static bars in explosive Atmospheres or in the presence of flammable dust vapors or gases
- Avoid contact with ionizing emitter points when energized
- Disconnect power before performing any maintenance procedure
- Monitor the motor amperage during slot adjustment to insure that current draw does not exceed recommended current. Amperage ratings are listed on the serial tag on the monitor

8. PARTS AND ACCESSORIES

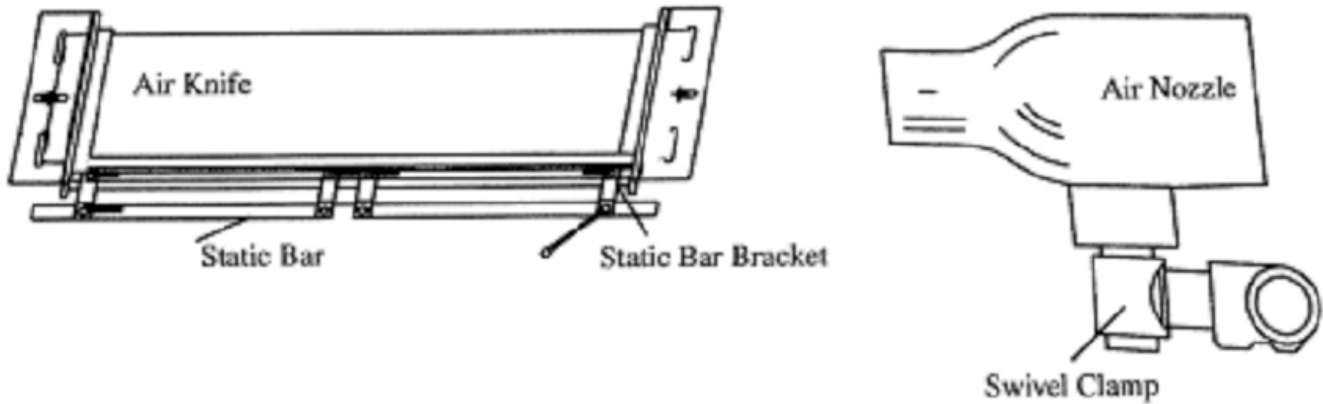

Figure 9. Magnum Force and Nozzle Replacement Parts

Description	Part Number
Air Knife	Contact Simco-Ion
Static Bar	Contact Simco-Ion
4" dia. Mounting Bracket Kit	5050659
6" dia. Mounting Bracket Kit	5050660
MEB Static Bar Bracket	4370572
IQ Power Static Bar Bracket	5051854
R50 Static Bar Bracket	4370808
Air Nozzle X075	4007619
Air Nozzle X125	4007618
Air Nozzle X050	4008341
Swivel Clamp 1"	4107371
Swivel Clamp 3/4"	4106660
4" dia. Flex Hose (8' long)	4800184
6" dia. Flex Hose (8' long)	4800186
4" Blast Gate	4670470
6" Blast Gate	4670469
4" dia. Hose Clamp	4670187
6" dia. Hose Clamp	4670184
Blower	Contact Simco-Ion
Motor	Contact Simco-Ion

Filter Element – use part number on Simco-Ion Blower Nameplate

9. WARRANTY

This product has been carefully tested at the factory and is warranted to be free from any defects in materials or workmanship. Simco-Ion will, under this warranty, repair or replace any equipment which proves, upon our examination, to have become defective within one year from the date of purchase.

The equipment being returned under warranty should be shipped by the purchaser to Simco-Ion, 2257 North Penn Road, Hatfield, PA 19440, transportation prepaid and insured for its replacement cost. Prior to returning any goods for any reason, contact Simco-Ion Customer Service at (215) 822-6401 for a Return Authorization Number (RMA). This number must accompany all returned items.

This warranty does not apply when the equipment has been tampered with, misused, improperly installed, altered, has received damage through abuse, carelessness, accident, connection to improper line voltage, or has been serviced by anyone other than an authorized factory representative.

The warranty does not apply when Simco-Ion parts and equipment have been energized by other than the appropriate Simco-Ion power supply or generator, or when a Simco-Ion power supply or generator has been used to energize other than Simco-Ion parts and equipment. Simco-Ion makes no warranty, expressed or implied, nor accepts any obligation, liabilities, or responsibility in connection with the use of this product other than the repair or replacement of parts stated herein.

Information in this publication supersedes that in all previous published material. Specifications are subject to change without notice.

Simco-Ion

2257 North Penn Road
Hatfield, PA 19440

(215) 822-6401

(800) 203-3419

www.simco-ion.com

customerservice@simco-ion.com

© 2023 Simco-Ion. Printed in the U.S.A.