



An ITW Company

Neutro-Vac[®] Web Cleaning System

INSTALLATION AND OPERATING INSTRUCTIONS

TABLE OF CONTENTS

1. SAFETY WARNINGS	1
2. INTRODUCTION	3
Vacuum Hoods	3
Dust Collectors	5
Receipt of Equipment	5
3. SPECIFICATIONS	5
4. INSTALLATION	6
Hood Assembly Installation	6
Hood Adjustments	7
Vacuum System (Ductwork)	7
Ductwork Installation for All Units	8
Power Supply for IQ Easy Static Bars	8
Power Supply for MEB Static Bars	8
Grounding the Power Supply for MEB Static Bars	8
Cable Routing (IQ Easy Bars)	9
Cable Routing (MEB)	9
High Voltage Connector (MEB)	10
Air Bars	10
Dust Collector Installation	11
Electrical Installation	12
5. OPERATION	16
Verify	16
Start Neutro-Vac Web Cleaning System	16
6. MAINTENANCE	17
Neutro-Vac Hood Assembly	17
Dust Collector Maintenance	18
7. TROUBLESHOOTING	24
Static Bar Operational Test	24
IQ Easy Power Unit Operational Test	24
F167 and F267 Power Unit Operational Test (MEB)	24
Dust Collector Troubleshooting	25
For Models DC66, DC75, DC84 and DC90 Bag Style Collectors	28
8. WARRANTY	29

1. SAFETY WARNINGS

PLEASE READ INSTRUCTIONS COMPLETELY BEFORE STARTING INSTALLATION.

ALL INSTALLATION AND MAINTENANCE OPERATIONS MUST BE PERFORMED BY QUALIFIED TECHNICAL PERSONNEL.



NOTE – Statements identified with a NOTE indicate precautions necessary to avoid potential equipment failure.



CAUTION – Statements identified with a CAUTION indicate potential safety hazards.



WARNING – Statements identified with WARNING indicate potential serious injury hazards.



CAUTION – Electrical Shock Hazard

High voltage is hazardous for people with a pacemaker



WARNING – Fire Hazard

Do not install or operate equipment in close proximity to any flammable solvents or flammable materials.



NOTE – This equipment must be correctly installed and properly maintained. Adhere to the following cautions for safe installation and operation:

1. Read instruction manual before installing or operating equipment.
2. Only qualified service personnel are to perform installation and repairs.
3. This equipment must be installed and maintained as outlined in this manual. Disconnect and lockout all power before servicing this machine, unless instructions state otherwise. Turn off web drive equipment and remove web, if possible, before performing maintenance.
4. Failure to properly ground the static bar power supply may result in an electrical shock hazard to personnel and inefficient operation of the equipment. Do not apply line power until all grounds and high voltage connections have been completed.
5. Do not pour alcohol on static bars or soak static bars in alcohol at any time or damage to the static bar may result.
6. Do not hang rags on static bar or a fire may result.
7. To avoid a potential fire hazard caused by sparks in the dust collector, do not mix combustible materials such as buffing line, paper, wood, dust, aluminum and magnesium with dust generated from grinding ferrous metals.

8. Under no condition should machine operator put a lit cigarette or any burning object into the hood or ducting of the dust control system.
9. When the materials being collected by the system create the risk of fire or explosion, the appropriate collection system design must be used to comply with all material (NFPA) and local fire codes. An individual familiar with all the appropriate fire hazards, equipment, and codes should be consulted to insure proper installation and compliance of the collection system.
10. Explosion relief vents are required on some applications. Consult with an insurance underwriter or a NFPA Manual (NFPA 68 Venting of Deflagrations - NFPA 91 Blower and Exhaust Systems) to determine proper vent size and ratio. Vents installed on dust control equipment within a building must be vented to the outside with ducting that meets the following specifications:
 - Cross-section area no smaller than the vent.
 - No longer than 10'.
 - Straight with minimal bends (to minimize chances of secondary explosion).
 - Fabricated from 16-gauge (or thicker) sheet steel.
11. Consult the proper authorities to determine proper venting methods. Simco-Ion's dust collectors do not contain explosion relief vents.
12. Consult and comply with all National and Local Fire Codes and/or other appropriate codes when determining the location and operation of dust collection equipment.
13. Air exhaust outlet at the top of the dust collector must not be blocked. Make sure materials are not stored over the exhaust opening.
14. Stand clear of the dust collector's exhaust fan during rotation.
15. Dust collector has a high center of gravity. Careful handling is required to avoid overturning dust collector during movement.
16. Personal safety equipment, like eye protection (goggles) or protective breathing apparatus (dust mask) should be worn during some of the installation and maintenance procedures involved with the dust collection system.

2. INTRODUCTION

Simco-Ion's Neutro-Vac is a web cleaning and dust collection system that incorporates active static elimination, aggressive particle agitation and vacuum removal of debris to provide efficient cleaning of webs, sheets or parts.

Neutro-Vac Systems consist of a vacuum hood, ducting and a dust collector. Vacuum hoods are designed to eliminate static charges and physically scour dust and debris from the surface of a web, sheet or part. Debris is vacuumed into the inlet slot, flows through the ducting then is deposited into the dust collector.

Vacuum Hoods

Vacuum hoods are a welded air-tight construction design that are available in a variety of different shapes and sizes. Two of the most common sizes are Top Draft and Side Draft. Top Draft hoods and Side Draft hoods are available in various configurations (see Figure 1).

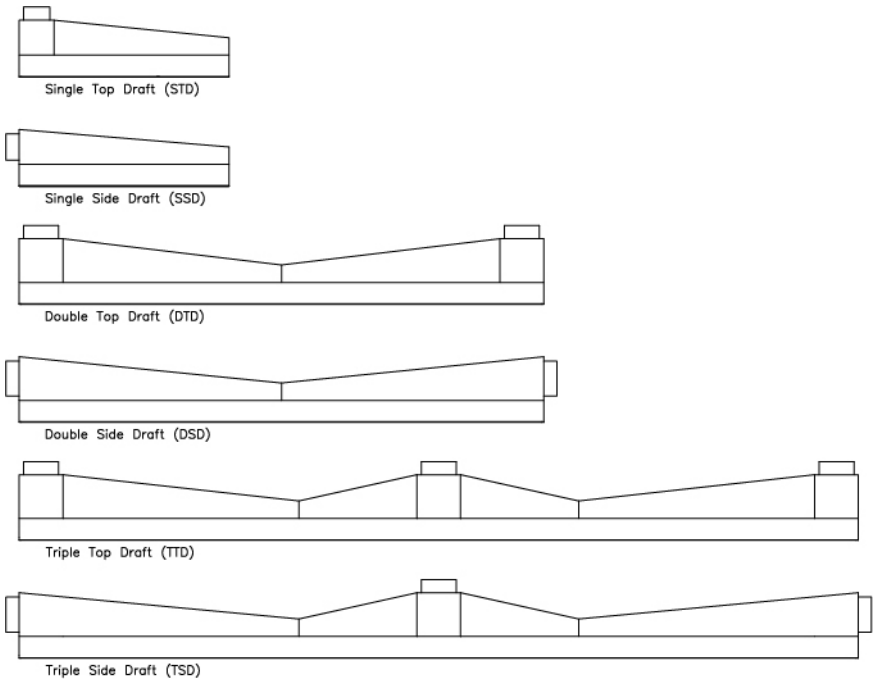

Figure 1: Various Top Draft and Side Draft Configurations

Vacuum hoods have two basic intake Options (see Figure 2):

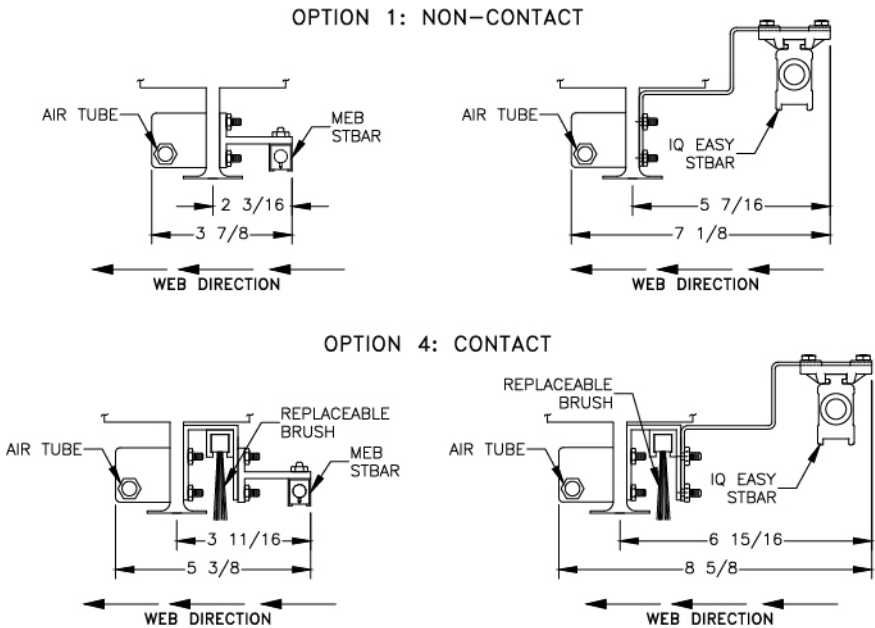

Figure 2: Vacuum Hood Intake Options

Option 1 – Non-Contact

Simco-Ion's static bars (IQ Easy or MEB) are used with a compressed air tube to eliminate static charges on webs and other materials. Particles are subjected to an aggressive blast of compressed air which lifts debris from the web. Debris is captured and drawn into the vacuum system through the inlet. This intake configuration is used on webs that cannot tolerate contact.

Typical applications include:

- Removal of slitting debris and static charges on plastic film.
- Removal of contamination and static charges during the converting process.
- Removal of contamination and static charges on film prior to adhesive application.

Option 4 – Contact

Simco-Ion's static bars (MEB or IQ Easy) are used with a compressed air tube to eliminate static charges on webs and other materials. After the web is neutralized it passes under a stiff bristle brush which loosens debris from the web. Particles are then subjected to an aggressive blast of compressed air which lifts debris from the

web. Debris is captured and drawn into the vacuum system through an inlet. This configuration is used in applications where web material can tolerate contact and requires aggressive cleaning.

Dust Collectors

Simco-Ion’s standard line of dust collectors provide high efficiency, intermittent or continuous-duty dust collection using either cartridge or bag filters. The cartridge filter units use automatic shaking action to clean the filters each time the unit is shut down. The continuous duty units use pulse jet airflow to purge the filters of dust. The bag filter units require a manual shaking by the collector operator. All models are acoustically lined inside the blower chamber for noise reduction.

Receipt of Equipment

1. Carefully remove the equipment from the packaging.
2. Inspect contents for damage that may have occurred during shipment. If any damage has occurred during shipment, the local carrier should be notified at once. A report should be forwarded to Simco-Ion, 2257 North Penn Road, Hatfield PA 19440, (215) 822-6401.
3. Empty the packaging to ensure that small parts are not discarded.

3. SPECIFICATIONS

Requirements		
Vacuum System	Vacuum Hood	1.2” of water
	Volume	8 CFM per inch of intake slot (1/4” slot width)
Compressed Air System	Pressure	5 psi minimum, 20 psi maximum
	Volume	0.25 SCFM per inch of intake slot (at 5 psi) 0.50 SCFM per inch of intake slot (at 10 psi) 1.00 SCFM per inch of intake slot (at 20 psi)
NOTE: Compressed air must be clean and dry. Hoses and fittings must be of adequate size to provide required airflow.		
High Voltage	IQ Easy Static Bar	Speed-T (24 VDC, 0.75A) Hybrid-T (24 VDC, 0.75A)
	MEB Static Bar Power Supply	F167 (120 VAC, 50/60 Hz, 0.25 A) F267 (230 VAC, 50/60 Hz, 0.12 A)
NOTE: Maximum 2 static bars or 200” total static bar length can be used with power supply models F167 and F267.		

4. INSTALLATION

Hood Assembly Installation

Locate hood(s) using the following guidelines:

- Locate near non-crowned (constant diameter) roller.
- Web must maintain a fixed location with respect to machine frame (i.e. not near a take-up roller or a roller that swings).
- Web must maintain constant tension where the hood assembly will be installed.
- Do not locate static bar(s) on the hood directly over a roller.
- Web must be in free air near static bar for the static eliminator to work (see Figure 3).

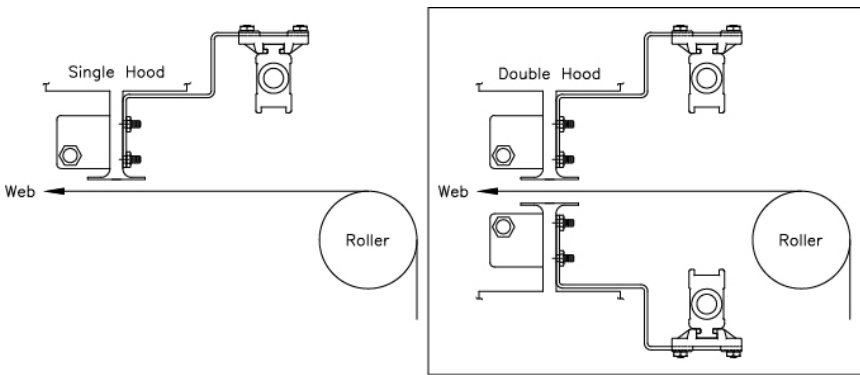

Figure 3: Hood Locating

Contact a Simco-Ion customer service representative for assistance if you have any questions on the proper location of the Neutro-Vac Hood assembly.

See Figure 3 to determine how to locate the hood so the web passes in the correct direction. If your hood is not configured for proper installation, switch the accessories:

1. Remove nuts securing mounting brackets to stud on intake slot.
2. Reverse order of accessories.
3. Replace nuts on studs to secure accessories.

To mount the hood use brackets or build a sturdy sub-frame that will center hood over the web and allow adjustment of intake slot from 0" (touching web) to 1" from web. Typical operating distance between the slot opening and web is 1/4" to 1/2". To accomplish this, hoods are supplied with brackets having slotted adjustment holes. The overall dimensional drawing of your hood will provide you with the dimensions needed for mounting and approximate hood weight.

The mounting frame must provide an electrical ground, or a separate ground connection must be connected to ensure proper operation of the static bar.

Hood Adjustments

Option 1 – Non-Contact

Hood(s) should be set with intake slot 1/2” from web. Adjust hood height using slotted holes in mounting brackets. At this distance, air bar pressure should be set to 5 psi. If more aggressive cleaning is desired and web tension allows, set intake slot 1/4” from web and increase air bar pressure to 10 psi.

It may be necessary to increase hood-web distance or adjust the flow regulating cutout for proper operation. Table 1 shows minimum and maximum air bar pressure for different hood-web distances.

Option 4 - Contact

Hood(s) should be set with intake slot 1/4” from web. Adjust hood height using slotted holes in mounting brackets.

Brush is mounted in a channel that may be moved up and down after loosening its mounting nuts. Adjust the brush so it makes very light contact with the web. Retighten mounting nuts.

At this distance, the air bar pressure can be set up to 20 psi for the most aggressive cleaning

Vacuum System (Ductwork)

Each ductwork system is unique. The following are general guidelines for installation:

- Use the shortest possible length of flexible hose to connect the hood to the vacuum system (typically 2' length).
- Secure flexible hose with hose clamps.
- Use a flow regulating cut-out on each hook-up stub that connects to a hood to allow each hood in system to be adjusted for air flow.
- Use rigid, smooth walled, galvanized pipe and fittings wherever possible to provide smooth air flow and reduce vacuum losses in ductwork.
- Use long sweep elbows.
- Avoid using tees and short radius elbows because they produce unacceptable vacuum losses.
- Use only ductwork recommended by Simco-Ion.
- Appropriate ductwork diameters are critical to airflow.

Ductwork Installation for All Units



CAUTION – Do not attempt to change the number or size of inlets. If the dust collector is operated with more than the maximum permissible inlet area, the motor and filters may become overloaded.



NOTE – When installing ductwork, use the shortest possible runs. Long radius elbows and at least 45-degree branches. Avoid the use of airflow tees.

Ductwork should be of a proper size to permit passage of the air velocities recommended for the material being collected. A complete selection of galvanized steel pipe elbows, branches and fittings are available from Simco-Ion. Stainless steel components are also available upon special order. If you require any assistance in the design or selection of ductwork, contact your local Simco-Ion representative.

1. Connect piping joints with sheet metal screws, rivets or solder.
2. Wrap each joint with a single layer of duct tape. This will insure a rigid, airtight system.

Power Supply for IQ Easy Static Bars

IQ Easy static bars are equipped with an integrated high-voltage power unit, ion emitters and status LEDs. They require a 24 VDC supply voltage to be provided via a 5-pin M12 connector. For detailed instructions, see the publication included with the static bars.

Power Supply for MEB Static Bars

The following are brief instructions for power supplies used with the MEB static bars. For detailed instructions, see the publication included with the power supplies.

1. Locate power supply where high voltage cable(s) from the static bar will reach.
2. Locate power supply where it is accessible but out of the way.
3. Do not cut high voltage cable(s) until everything has been mounted.
4. Orient / turn power unit so HV connection ports are facing downward.

The power supply is designed for flat surface mounting. It can easily be mounted using flanges at the base of the unit. Proper grounding of the power supply is essential for safe and efficient operation.



CAUTION – Electrical Shock Hazard

Failure to properly ground the power supply may result in an electrical shock hazard to personnel and inefficient operation of the equipment. Do not apply line power until all grounds and high voltage connections have been completed.

Grounding the Power Supply for MEB Static Bars

There are three ways to ground the power supply:

Method 1

Power unit is equipped with a 3-conductor line cord. On power supplies designed for 120 VAC operation, the line cord is fitted with a standard 3-prong plug and should be plugged into a 3-terminal grounded receptacle. On power supplies designed for 220 VAC operation, the AC line cord is not normally supplied with the plug. The green wire provides the ground connection to the power supply and should be connected to a true ground.

Method 2

Bolt power supply to a machine frame that is properly grounded.

Method 3

Connect the ground wire between ground lug on the power supply and a true ground such as a cold-water pipe or grounded electrical conduit.



WARNING – Power supply should be connected to an AC/DC line that is turned on and off with machine operation. This will ensure the high voltage power supply is deactivated when the machine is off. If this is not possible, the use of a separate, fused disconnect for the power supply is recommended.

Cable Routing (IQ Easy Bars)

For detailed instructions, see the publication included with the static bars.

Cable Routing (MEB)

The high voltage cables should not contact any grounded parts of the machine frame. Cable supports are used to guide the high voltage cable from the static bar, along machine frame and to the power supply. Cables should be kept at least 1/4" away from:

- Machine frame
- Machine parts
- Walls
- Floor

To Install Cable Supports

1. Press split plastic bushing out of metal support and apply bushing to cable at desired location.
2. Drill a 13/64" diameter hole through machine frame and mount the support.
3. Press bushing with cable back into support.



NOTE – Be sure that a cable support is positioned so that all strain and motion from the cable where it enters the static bar and the power supply is minimized.

High Voltage Connector (MEB)

Attach a connector to the high voltage cable coming from each static bar. Allow approximately 3" of additional cable on the connector before cutting.

1. Measure and strip 1/2" insulation from end of cable. Straighten conductor strands.
2. Slide knurled plug onto cable with threaded end toward end of cable as shown in Figure 4.
3. Slide connector body on cable with setscrew hole positioned toward end of cable.
4. Slide high voltage connector over conductor until it butts against cable insulation. Make certain all conductor strands are inside connector.
5. Line up set screw holes in connector body with high voltage connector. Insert and tighten set screw. Pull firmly on connector body to make certain set screw is well seated.
6. Screw contact spring (closed end first) onto high voltage connector

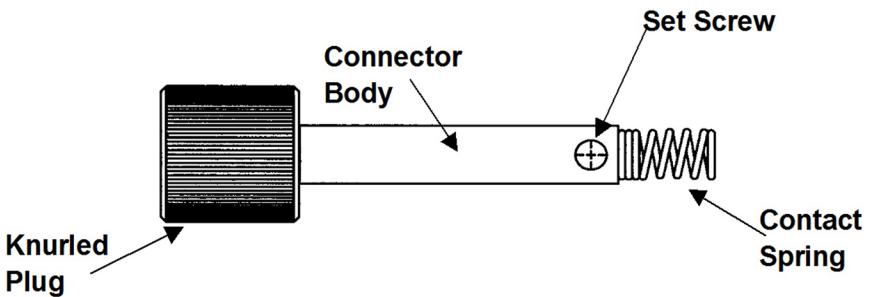

Figure 4: High Voltage Connector (MEB)

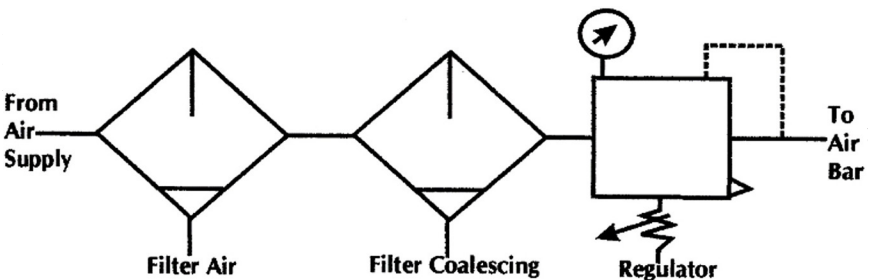

Figure 5: Air Bar Component Connection

The recommended tubing to hook up the air bars is polyethylene, polypropylene or nylon with a minimum of 100 psi working pressure. This tubing is recommended to provide a clean and safe connection between the air preparation components and Neutro-Vac hood. Use Table 1 below to determine what size tubing and fittings to use.

Pipe Size of Fitting	I.D. of Tubing	Air Bar Length
1/4 NPT	1/4"	< 48"
3/8 NPT	3/8"	> 48"

Table 1: Sizing Chart



NOTE – If the tubing or fitting is smaller than specified, airflow will be restricted, and performance will be unacceptable.

Dust Collector Installation

DCX-500, DC550, DC1200, DC1500 and DC3000 Cartridge Style Collectors

Duct enters the dust collector through the cabinet inlet and then passes through a tight mesh screen on the outside of the filter(s). The screen (spaced 1" away from the filter media) catches fibrous dust while fine particles pass through the screen and collect on the outside surface of the pleated filter cartridge. Clean air flows up through the center of the filter cartridge into the blower then through the silencer section of the cabinet. Clean air exits through the top clean air outlet.

DC66, DC75, DC84, and DC90 Bag Style Collectors

Dust laden air first enters through the dirty air inlet and then passes through the cabinet where the dust is collected on the outside surface of the filter media. The cleaned air then flows up through the center of the filter media and into the clean air plenum. It enters the blower fan and exits through the blower exhaust located on the roof of the cabinet dust collector (DC66, DC75 and DC84). The DC90 uses an external motor/blower package so the exhaust is on the blower housing which sits on top of the cabinet.

*DC-aP**J**b Continuous Duty Collectors (a = # of horizontal columns of filters, b = # of filters)*

There is a separate instruction manual for these collectors. Basically, dust laden air enters the top of the dirty air chamber. The debris settles to the bottom of the filter cabinet in a hopper. The hopper normally fits over a 55-gallon drum into which the debris may be dumped while the collector continues to operate. The drum may be taken away from the area for cleaning while the collector continues to run, storing debris in the hopper.

Debris will be seen on the outside of the filters, but it cannot penetrate the medium, allowing it to be blown off the surface by a strong, reverse blast of air. The degree of filter blockage is monitored so that the cleaning process is started at a pre-selected point and ceases at a second pre-selected level.

The motor/blower package is mounted outside of the housing and may be fitted with a silencing enclosure. (See manual #5200712 for Continuous Duty System.)

Dust Collector Installation for All Units



CAUTION – Dust collectors have a high center of gravity. Careful handling is required to avoid overturning during moving. The collector must be kept in the up-right position when moving or damage may occur.



WARNING – Fire Hazard

When dust collectors are used to collect explosive or fire risk dust, the dust collector should be located outside the building. An individual familiar with fire extinguishing equipment, flammable material hazards and local fire codes should be consulted for recommendations and installation of the proper fire extinguishing equipment.



WARNING – Explosion relief vents are required for some applications. Consult with an insurance underwriter or a NFPA Manual (NFPA 68 Venting of Deflagrations - NFPA 91 Blower and Exhaust Systems) to determine proper vent size and ratio. Vents installed on dust control equipment within a building must be vented to the outside with ducting that meets the following specifications:

- Cross section area no smaller than the vent
- No longer than 10'
- Straight with minimal bends (to minimize chances of secondary explosion)
- Fabricated from 16-gauge (or thicker) sheet steel

Consult the proper authority to determine proper methods of venting. Dust collectors do not contain explosion relief vents.

Consult and comply with all National and Local Fire Codes and/or the appropriate codes when determining the location and operation of dust collection equipment.

Place the dust collector as close as possible to the dust source in non-hazardous applications.



NOTE – Various inlet sizes are available. Please specify size required at the time of ordering your Neutro-Vac System. If unit is operated with more than maximum permissible inlet area, the fan motor may become overloaded or dust may settle within the ductwork due to low carrying velocities.

Electrical Installation



WARNING – A qualified electrician must perform all electrical work.

1. Make electrical connections to disconnect switch (customer-supplied), fan starter, fan motor and control box (reference Figures 6, 7, 8, 9 & 10). See electrical wiring diagram inside the control box cover (reference Figure 11). Fan access is located through the top door of the cabinet.



WARNING – Verify that the air exhaust at the top of the collector is not blocked. Verify that materials are not stored over the exhaust opening. Stand clear of fan exhaust during rotation.

2. Start fan motor and visually verify that the blower wheel is turning in the direction indicated by the rotation arrow on the blower housing. Incorrect rotation direction will cause up to a 60% decrease in rated air volume while requiring more than its rated horsepower. If the blower rotation is incorrect, rotation must be corrected by switching any two leads (3 phase only).

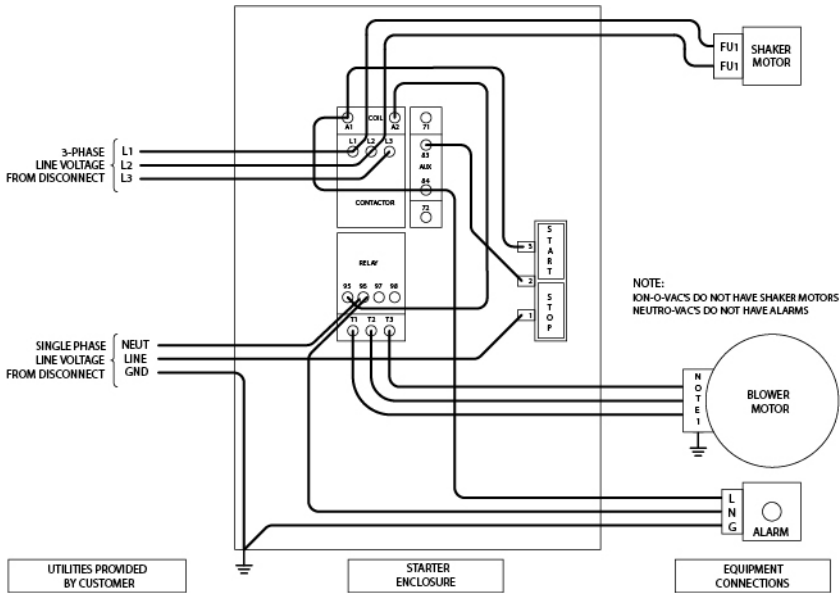

Figure 6: Starter Enclosure Wiring With Push Button Start/Stop Switch

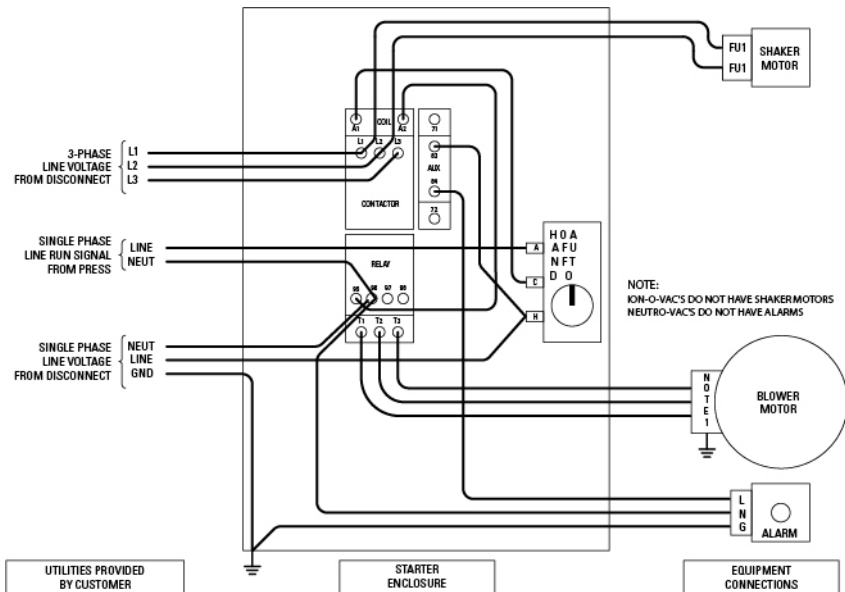

Figure 7: Starter Enclosure Wiring With Rotating On/Off/Auto Switch (120V Coil)

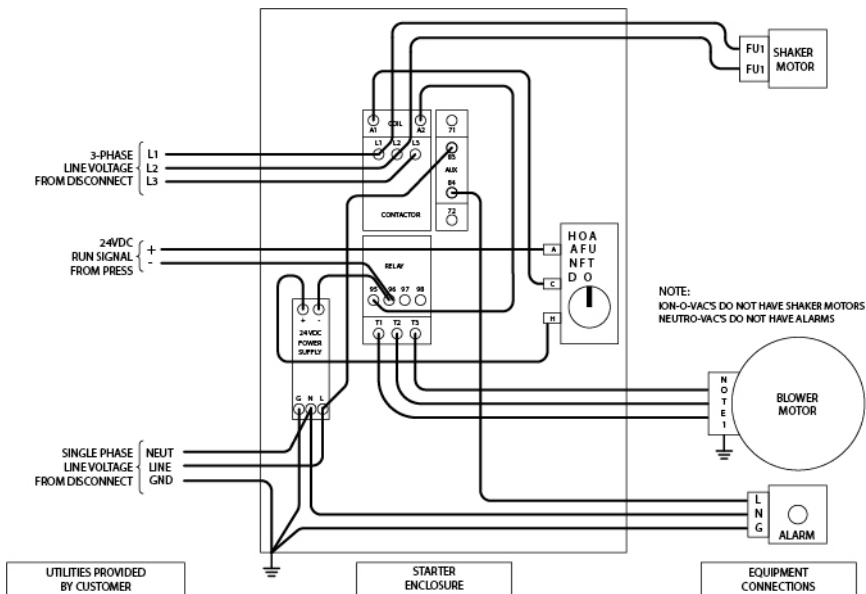

Figure 8: Starter Enclosure Wiring (24 VDC Coil With PS) With Rotating On/Off/Auto Switch

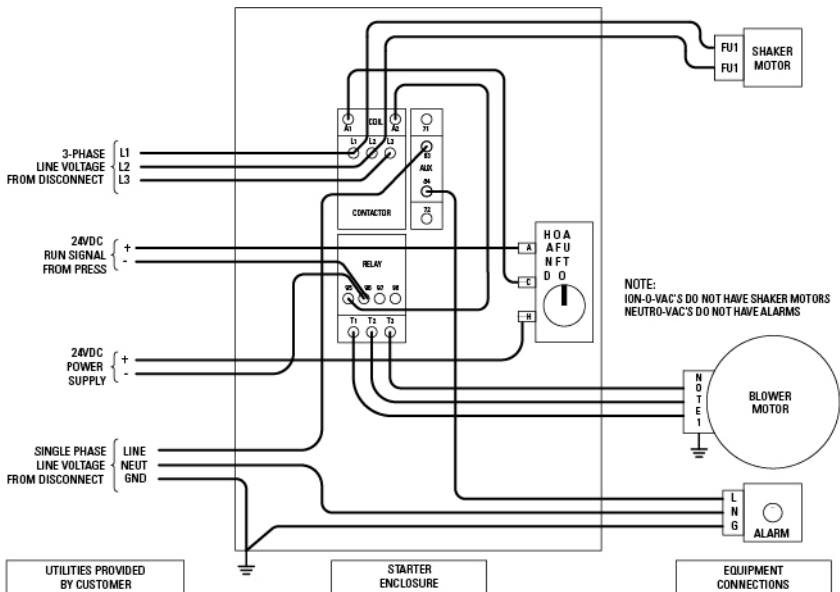

Figure 9: Starter Enclosure Wiring (24 VDC Coil Without PS) With Rotating On/Off/Auto Switch

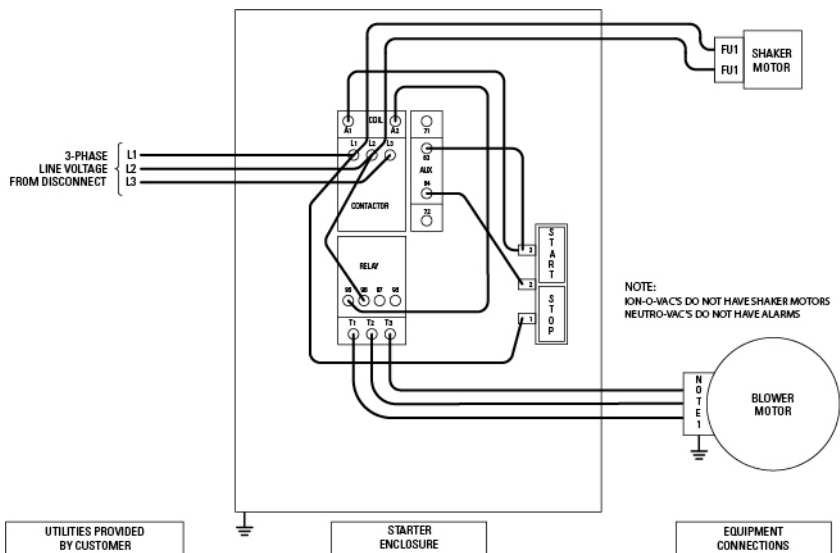

Figure 10: Starter Enclosure Wiring With Push Button Start/Stop Switch if Line & Coil Voltage are Equal

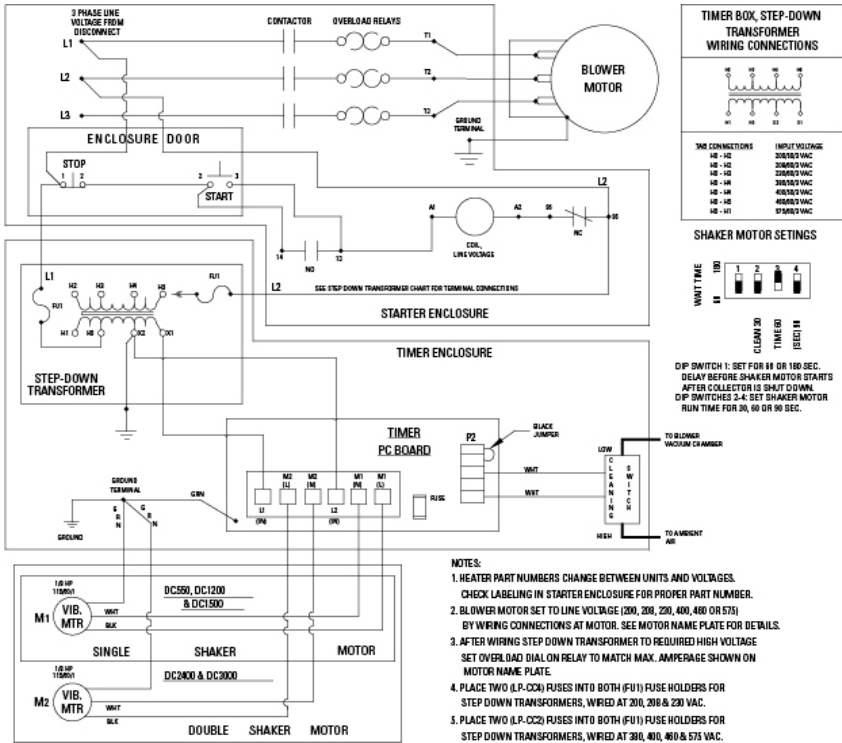

Figure 11: Wiring Connections

5. OPERATION

Verify

- Hood is positioned properly over web.
- Static bars are connected to power supply.
- Power supply is properly grounded.
- Air bar components are connected properly.
- Air supply is clean and dry.
- Ductwork to dust collector is installed properly.
- Dust collector is in the most appropriate location for your application.
- Exhaust outlets on dust collector are free of obstructions.

Start Neutro-Vac Web Cleaning System

- Plug power supply into three-prong, grounded outlet.
- Turn on air supply.
- Plug dust collector into three-prong, grounded outlet.
- Turn dust collector fan on.

6. MAINTENANCE

Neutro-Vac Hood Assembly



WARNING – Disconnect and lock out power to the Neutro-Vac Web Cleaning System before performing all maintenance procedures unless otherwise instructed. Turn off web drive equipment and remove web (if possible) before performing maintenance.

Weekly

- Examine intake slot of Neutro-Vac hood for even in-draft of air.
- Remove any obstructions in intake slot.



NOTE – At regular intervals there are small spacers welded in place to maintain the slot spacing. Do not remove the spacers.

- Examine air bar for even flow (if equipped).
- Examine brush for proper condition and contact with web (if equipped).
- Adjust brush for proper contact with web (if equipped).
- Examine hardware for security.

Monthly

- Wipe exposed surfaces.
- Remove debris from non-exposed surfaces using compressed air.
- Perform static bar cleaning procedure.

The static bar must be cleaned monthly to maintain optimal system performance. The Static Bar Operation Test must be performed as needed and no less than annually.

If bar is extremely dirty when cleaning, increase frequency to weekly. In very dirty environments, it may be necessary to clean daily or at the end of each shift.

To Clean Static Bar

1. Using compressed air, blow out holes on both front and back of static bar. This will remove dirt, dust and particulate collected inside bar.
2. Using a stiff nylon brush, scrub area around each pin, removing as much debris as possible.
3. Use Isopropyl alcohol only (other solvents may damage plastic) applied with a clean cloth to remove paint and ink build up.



CAUTION – Do not pour alcohol on bar or soak bar in alcohol at any time or damage to the inner bar assembly may result.

4. Wipe off solvent using a clean rag.



WARNING – Do not hang rags on static bar or a fire may result.

5. Clean points using a stiff nylon brush.

Accessory Mounting

If it becomes necessary to remove the static bar, air bar, or brush for service, be sure to replace it in the correct location relative to the web.

1. The MEB or IQ Easy Static Bar must be mounted with its points facing the web and centered between mounting brackets. Secure the static bar with set screws in the mounting bracket.
2. When replacing the air bar, holes must be pointed directly at the web (perpendicular to its surface). Secure the air bar with set screws in mounting brackets.

Dust Collector Maintenance



WARNING – Disconnect and lockout power to the Neutro-Vac Web Cleaning System before performing all maintenance procedures unless otherwise instructed. Turn off web drive equipment and remove web (if possible) before performing maintenance.

All Models

1. Empty collector drawer or drum when approximately two-thirds full.
2. Remove any dust settled at the bottom of the dust compartment on a weekly basis.
3. Follow the manufacturer's directions for motor maintenance. If your motor requires servicing under the manufacturer's warranty, contact an authorized service center.

DCX500, DC550, DC1200, DC1500 and DC3000 Cartridge Style Collector
(see Figure 12)

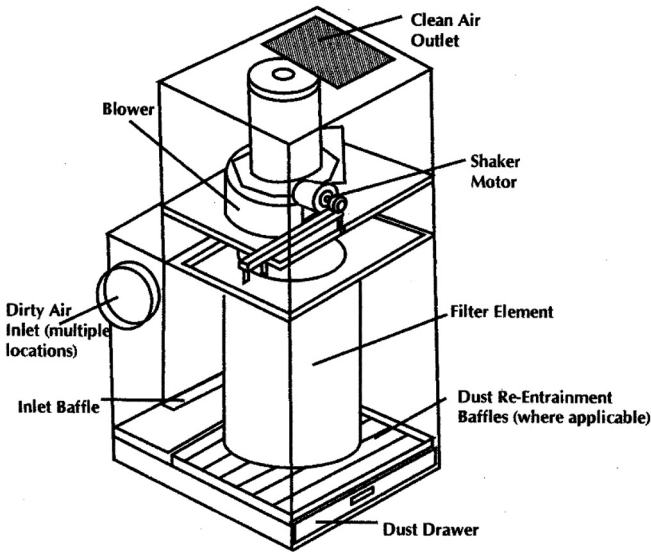

Figure 12: Dust Collector (Cartridge Style)

Filter Cleaning

Dust collectors are off-line cleaning. Cleaning is done only after the fan is shut off. The control timer is automatically energized to start the cartridge cleaning sequence when the fan is shut off. After a 30 second pause to allow fan to run down, the vibrator motor starts and runs for a preset time, shaking dust from the filter. A diaphragm at the bottom of the filter opens after the fan is shut off allowing fine dust particles collected on the filter media to escape. The dust falls into the dustpan or optional hopper for disposal.

Power to the collector must remain ON to operate cleaning mechanism. The dust collector is factory set to always clean after the fan is shut off.

If fine mesh or filter becomes plugged with fibrous material, it can be removed and cleaned. To remove mesh:

1. Pull apart Velcro® at seam.
2. Remove mesh and gently clean by hand, taking care not to damage the mesh.



WARNING – Manually cleaning the screen exposes operator to collector contaminant. Wear safety goggles and dust respiring-breathing apparatus.

3. Reinstall screen by butting it up against the upper end cap of filter. Stretch screen tight before sealing Velcro® edges. The screen must not extend below the lower edge of the filter.

Filter Replacement

Filter replacement exposes operator to collector contaminant. Wear safety goggles and dust respiring-breathing apparatus.

1. Disconnect electrical power.
2. Loosen knobs on bottom door and remove door (knobs remain attached to the door).
3. Loosen the four knobs supporting the filter.
4. Rotate retaining ring counter clockwise to release ring and filter.



WARNING – Filter may be heavy due to accumulation of dust. Be careful the filter doesn't drop when the ring is rotated.

5. Remove the support ring from filter.
6. Check gasket surface on shaker panel for dust. Clean if necessary.
7. Install supplied screen on replacement filter.
8. Install new filter on shaker panel, reusing the filter support ring.
9. Tighten the filter support ring by hand.
10. To insure an airtight seal, inspect the door gasket on the cabinet. Repair or replace if necessary.
11. Reinstall door and tighten knobs securely by hand.
12. Connect electrical power and resume operation.



NOTE – A slight bleed-through on any new filter is normal and will quickly disappear as the filter seasons. If bleed through persists, contact your Simco-Ion representative.

DC66, DC75, DC84, and DC90 Bag Style Collectors (see Figure 13)

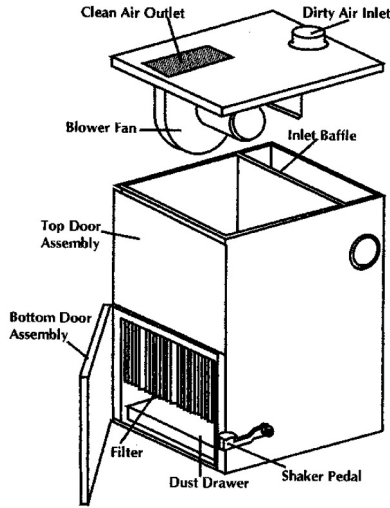

Figure 13: Dust Collector (Bag Style)

Filter Cleaning

Cabinet collectors are off line cleaners. Cleaning cannot take place until 60 seconds after the blower is turned off.



NOTE – Attempting to clean the filter while the collector is operating will cause the dust to penetrate the filter media and shorten filter life.



WARNING – Filter cleaning exposes operator to collector contaminant. Wear safety goggles and dust respiring-breathing apparatus.

Filters are chemically treated for fire resistance. They will not ignite unless exposed to a continuous flame. You should not however, attempt to collect materials such as lint and grinding dust in the same collector.



WARNING – To avoid a potential fire hazard caused by sparks in the dust collector, do not mix combustible materials such as buffing line, paper, wood, dust, aluminum and magnesium with dust generated from grinding ferrous metals.

Under no condition should machine operator put a lit cigarette or any burning object into the hood or ducting of the dust control system.

The filters in the bag type dust collector are semi-permanent and will provide long, efficient service when routine maintenance is performed.

1. Shake the filters to remove any clinging material daily. To perform this operation, push down vigorously on the filter shaker lever located on the side of the cabinet. On the hopper model, pull handle firmly.
2. Hand brushing may be required if the collected material sticks to the filters. Care must be taken to prevent the tearing or puncturing of the filter cloth. If the filters become saturated with oil, they must be dry cleaned.
3. Replace filters every two years when used under normal operating conditions. Filters should not be removed except for dry cleaning or replacement. When ordering replacement filters, be sure to include the model and serial number of your dust collector.

Filter Replacement

1. Disconnect electrical power.
2. Remove upper and lower doors.
3. Remove and discard set screws and hold down channels.
4. Remove old bags.
5. Clean bottom of cabinet ledge with stiff brush.
6. Remove and empty dustpan.
7. Remove banded replacement filter from box.



NOTE – DO NOT remove bands from filter.

8. Fully loosen wing screws.
9. Move slide latches to the rear, away from gasket.
10. Insert banded replacement filter over shaker bar.
11. Rest banded replacement filter on shaker bar.
12. Cut and remove bands.
13. Remove cardboard protectors.
14. Insert one hand midway under each side of the filter.
15. Push the filter to bottom of cabinet filter frame.
16. Place one hand in the center of filter.
17. Hold filter against bottom of cabinet ledge.
18. Push each slide latch over cabinet ledge. DO NOT tighten wing screws.
19. Adjust filter for good fit.
20. Finger tighten wing screws.
21. Remove support bar from box.
22. Place support bar over center of filter.
23. Insert small wing screw through holes in support bar.
24. Hand tighten all wing screws.

25. Inspect filter seal.
26. Insert clean dustpan.
27. Install doors.
28. Connect electrical power and resume operation.

DC-aP**J**b Continuous Duty Collectors (a = # of horizontal columns of filters, b = # of filters)

For detailed instructions, see the publication included with the Continuous Duty Dust Collectors (5200712).

7. TROUBLESHOOTING

Static Bar Operational Test

Equipment needed:

- TensION Voltage Detector (Simco-Ion P/N: 4050556)



WARNING – HIGH VOLTAGE. Refer testing to qualified personnel.

1. Hold TensION with probe end facing static bar.
2. Touch probe to ionizing point on static bar.

If ionizing point is operating properly, an orange-red glow will be visible through the tip of the TensION Voltage Detector.

If test produces no indication of ionization, perform static bar cleaning procedure (see MAINTENANCE section) then check affected points for metal fragments. Repeat the static bar operational test.

If static bar checker shows no indication of ionization on any points, perform power supply test.

If it is determined that the power supply is operative, and more than one static bar is in use, locate the faulty bar.



CAUTION – Power supply must be turned off during disconnection and reconnection of static bar.

1. Disconnect all but one static bar from the high voltage terminal.
2. Use TensION Voltage Detector to test several points on the bar. If orange-red glow occurs, the bar is functioning properly. Disconnect that bar and reconnect next bar. Check all bars until faulty bar(s) is located by no glow.

IQ Easy Power Unit Operational Test

For detailed instructions, see the publication included with the static bars.

F167 and F267 Power Unit Operational Test (MEB)

Equipment needed:

- Multimeter – i.e. Fluke Model 70 Series or equivalent
- High Voltage Probe - i.e. Fluke Model 80K or equivalent with minimum 20 KVAC rating



WARNING – HIGH VOLTAGE. Refer testing to qualified service personnel. Failure to do this can affect a product's operation and can result in personal injury.

1. Verify power supply is off and static bar(s) are disconnected.
2. Set multimeter for AC voltage so that it can read 20KVAC full scale. Connect high voltage probe to multimeter and connect ground lead on high voltage probe to ground.
3. Connect a short (approx. 4”) piece of stiff wire to contact on end of high voltage probe.
4. Insert wire into high voltage connector contacting screw head inside high voltage connector on power supply.
5. Turn on power supply. Operative voltage should be between 7500 VAC and 8100 VAC. The power supply is not functioning properly if it is not operative between these voltages.



NOTE – Input voltage to power supply must be the same as on power unit label.

6. Turn off power supply.
7. Remove high voltage probe from connector in power supply.

Dust Collector Troubleshooting



WARNING – A qualified electrician must perform all electrical work. Failure to do this can affect a product’s operation and can result in personal injury.

If Blower Motor Will Not Start	
Cause	Remedy
Proper wire size was not used	Rewire per local and national codes
Motor is not wired correctly	Rewire, referring to motor wiring diagram located on motor
Unit is not wired for available voltage	Correct wiring for proper input voltage
Input circuit down	Check input to motor circuits for voltage on all leads



NOTE – Make sure power to the control board remains on when the unit blower is turned off. If all power is disconnected from the unit, the shaker mechanism will not operate.

Simco-Ion’s Dust Collectors are designed to make maximum use of the motor’s horsepower, but they are not under powered. Any motor that indicates an amperage draw more than 10% of the manufacturer’s recommendation on the nameplate is overloaded. Overloading may be caused by one or more of the conditions under “If blower motor will not start”.

If Blower Motor Starts, But Does Not Keep Running	
Cause	Remedy
Incorrect starter heater elements are installed	Replace with proper heater elements
Collector doors are off or not closed tightly	Close doors properly
Slide gate or hopper exits are not closed properly	Close gate or exits properly
Inlets are too large for collector rating	Call your local Simco-Ion Representative
Insufficient supply voltage	Check the supply voltage to verify that it meets the motor manufacturer requirements on the nameplate

Insufficient Air Flow	
Cause	Remedy
Fan rotating backwards	<p>Change the fan rotation (for three-phase only):</p> <ol style="list-style-type: none"> Disconnect dust collector from electrical outlet Remove the top door assembly Look at the rotation sticker on the fan housing for proper rotation direction Change the motor rotation by interchanging any two supply leads (three-phase only). On single-phase motors, the internal wiring will have to be changed. Reference motor wiring diagram Replace top door assembly Reconnect dust collector to electrical outlet
Ducting collapsed or plugged	<ul style="list-style-type: none"> Remove and replace collapsed ducting Remove and clean out debris that is blocking ducting
Improper duct size or too much flexible ducting	Contact your local Simco-Ion Representative
Fan exhaust is restricted	<ul style="list-style-type: none"> Remove the debris that is blocking the fan exhaust area Remove all loose material stored on top of the collector Incorrect starter heater elements are installed
Manual shaker mechanism is not working	Replace the broken foot or hand pedal. If the roll pin is sheared, reference the replacement parts section of this manual
Filter is plugged with fibrous material	<ul style="list-style-type: none"> Disconnect dust collector from electrical outlet Empty the dustpan, hopper or drum/ pail area Reinstall the drum/pail or dustpan after emptying and secure all the doors. Dustpans, drum or pails should be emptied when 2/3 full Reconnect dust collector to electrical outlet

Automatic Shaker Mechanism Not Working	
Cause	Remedy
No input voltage to the transformer	Using a voltmeter, check for voltage at the terminals H1 and H4 on the transformer. If there is no input voltage, check and repair the supply lines, fuses, etc.
No output voltage to the transformer	Using a voltmeter check the output voltage at terminal X1 and X2 on the transformer, (must be 115 volts AC). If there is no output voltage, replace the transformer. With a volt ohmmeter: <ul style="list-style-type: none"> a. Check the fuse inside of the electrical control box b. Check for input and output voltage c. Disconnect dust collector from electrical outlet d. Replace the fuse with one of equal value if input voltage is okay, but there is no output voltage e. Check the shaker mechanism for mechanical binding or any debris lodged in the shaker bar f. Remove the bottom door assembly and inspect. Remove debris or restriction
Interval timer has failed	<ul style="list-style-type: none"> • Check with a volt ohmmeter for voltage on the interval timer T1 terminal after the 60 second elapsed time interval • Check the output voltage to the shaker motor on the T2 terminal if the input voltage is okay • Replace the interval timer if there is no output voltage
Shaker motor relay has failed	Check with a volt ohmmeter for voltage at the relay input terminal #4 after the 60 second elapsed time interval: <ul style="list-style-type: none"> • Check voltage on the relay terminal #2 • If there is no output voltage, replace the shaker motor relay
Capacitor has failed	Check with a volt ohmmeter for input voltage at the input terminal of the capacitor after the 60 second elapsed time interval: <ul style="list-style-type: none"> • Check the output voltage on the capacitor terminal • Replace the capacitor if input voltage is okay but there is no output voltage
1/10th hp gear shaker motor has failed	<ul style="list-style-type: none"> • Check the feed-line circuits to the shaker motor with a volt ohmmeter • Replace the shaker motor if all the terminals and components are okay but the shaker motor still does not run

For Models DC66, DC75, DC84 and DC90 Bag Style Collectors

Problem	Cause	Remedy
<p>Shaker motor runs but filters are not being cleaned</p>	<p>Coupling between the shaker motor and shaker bar assembly damaged, missing or loose</p>	<ul style="list-style-type: none"> a. Disconnect dust collector from electrical outlet b. Remove the bottom door assembly and check coupling, connects, shaker motor and shaker bar c. Tighten the setscrews in the coupling to the shaft flats on the shaker motor and the shaker bar assembly if loose d. Replace setscrews if damaged or missing e. Reconnect dust collector to electrical outlet
<p>Shaker motor tries to start but blows fuse</p>	<p>Shaker bar may be blocked by debris or filter bags have become lodged between shaker bar and the cabinet wall</p>	<ul style="list-style-type: none"> a. Disconnect dust collector from electrical outlet b. Remove the bottom door assembly c. Check for and remove any debris that is blocking the shaker bar d. Check the filter bag at the ends of the shaker bar e. Remove and replace the shaker bag if lodged (see Maintenance Section of this manual) f. Reconnect dust collector to electrical outlet

8. WARRANTY

This product has been carefully tested at the factory and is warranted to be free from any defects in materials or workmanship. Simco-Ion will, under this warranty, repair or replace any equipment that proves, upon our examination, to have become defective within one year from the date of purchase.

The equipment being returned under warranty should be shipped by the purchaser to Simco-Ion, 2257 North Penn Road, Hatfield, PA 19440, transportation prepaid and insured for its replacement cost. Prior to returning any goods for any reason, contact Simco-Ion Customer Service at (215) 822-6401 for a Return Authorization Number. This number must accompany all returned items.

This warranty does not apply when the equipment has been tampered with, misused, improperly installed, altered, has received damage through abuse, carelessness, accident, connected to improper line voltage, or has been serviced by anyone other than an authorized factory representative.

The warranty does not apply when Simco-Ion parts and equipment have been energized by other than the appropriate Simco-Ion power supply or generator, or when a Simco-Ion power supply or generator has been used to energize other than Simco-Ion parts and equipment. Simco-Ion makes no warranty, expressed or implied, nor accepts any obligation, liabilities, or responsibility in connection with the use of this product other than the repair or replacement of parts stated herein.

Simco-Ion

2257 North Penn Road
Hatfield, PA 19440

(215) 822-6401

(800) 203-3419

www.simco-ion.com

customerservice@simco-ion.com

© 2019 Simco-Ion. Printed in the U.S.A.